



## NOTICE OF PUBLIC MEETING of the SOMERSET ACADEMY OF LAS VEGAS FINANCE COMMITTEE

---

NOTICE IS HEREBY GIVEN THAT THE SOMERSET ACADEMY OF LAS VEGAS FINANCE COMMITTEE WILL CONDUCT A PUBLIC MEETING ON FEBRUARY 2, 2024 AT 12:00 P.M. VIA ZOOM. THE PUBLIC IS INVITED TO ATTEND.

JOIN ZOOM MEETING:

[HTTPS://US02WEB.ZOOM.US/J/89928349204](https://us02web.zoom.us/j/89928349204) MEETING ID: 899 2834 9204 OR VIA PHONE  
+13462487799 +16694449171

ATTACHED HERETO IS AN AGENDA OF ALL ITEMS SCHEDULED TO BE CONSIDERED. UNLESS OTHERWISE STATED, THE COMMITTEE CHAIRPERSON MAY 1) TAKE AGENDA ITEMS OUT OF ORDER; 2) COMBINE TWO OR MORE ITEMS FOR CONSIDERATION; OR 3) REMOVE AN ITEM FROM THE AGENDA OR DELAY DISCUSSION RELATED TO AN ITEM.

REASONABLE EFFORTS WILL BE MADE TO ASSIST AND ACCOMMODATE PHYSICALLY DISABLED PERSONS DESIRING TO ATTEND OR PARTICIPATE AT THE MEETING. ANY PERSONS REQUIRING ASSISTANCE MAY CONTACT DENA THOMPSON AT (702) 431-6260 OR [DENA.THOMPSON@ACADEMICANV.COM](mailto:DENA.THOMPSON@ACADEMICANV.COM) TWO BUSINESS DAYS IN ADVANCE SO THAT ARRANGEMENTS MAY BE CONVENIENTLY MADE.

DENA THOMPSON IS THE CONTACT PERSON FOR THE MEETING AGENDA, SUPPORT MATERIALS, AND MINUTES. THE MATERIALS ARE AVAILABLE VIA EMAIL AT [DENA.THOMPSON@ACADEMICANV.COM](mailto:DENA.THOMPSON@ACADEMICANV.COM), BY VISITING THE SCHOOL'S WEBSITE AT [HTTPS://SOMERSETACADEMYOFLASVEGAS.COM/](https://somersetacademyoflasvegas.com/), OR AT 6630 SURREY ST., LAS VEGAS, NV 89119 FOR COPIES OF THE MEETING AUDIO, PLEASE EMAIL [DENA.THOMPSON@ACADEMICANV.COM](mailto:DENA.THOMPSON@ACADEMICANV.COM).

PUBLIC COMMENT MAY BE LIMITED TO THREE MINUTES PER PERSON AT THE DISCRETION OF THE CHAIRPERSON..



*We prepare students to excel in academics and attain knowledge through life-long learning by dedicating ourselves to providing equitable, high-quality education for all students. We promote a culture that maximizes student achievement and fosters the development of accountable 21st Century learners in a safe and enriching environment.*

**COMMITTEE MEMBERS**

**WILL HARTY  
JILL DAYNE  
JOHN BENTHAM**

**FINANCE COMMITTEE MEETING  
FEBRUARY 2, 2024**

**AGENDA**

- 
1. **CALL TO ORDER AND ROLL CALL**
  2. **PUBLIC COMMENT** *(NO ACTION MAY BE TAKEN ON A MATTER UNDER THIS TIME OF THE AGENDA UNTIL THE MATTER ITSELF HAS BEEN SPECIFICALLY INCLUDED ON AN AGENDA AS AN ITEM UPON WHICH ACTION WILL BE TAKEN.)*
  3. **ACTION AND DISCUSSION ITEMS** *(ACTION MAY BE TAKEN ON THOSE ITEMS DENOTED "FOR POSSIBLE ACTION")*
    - a. REVIEW AND APPROVAL OF THE MINUTES FROM THE OCTOBER 20, 2023 FINANCE COMMITTEE MEETING (FOR POSSIBLE ACTION)
    - b. REVIEW AND DISCUSSION OF SOMERSET ACADEMY FINANCIAL PERFORMANCE (FOR DISCUSSION)
    - c. REVIEW AND RECOMMEND APPROVAL OF 2022/2023 SINGLE AUDIT (FOR POSSIBLE ACTION)
    - d. REVIEW AND RECOMMEND APPROVAL OF NORTH LAS VEGAS SHADE STRUCTURE (FOR POSSIBLE ACTION)
    - e. REVIEW AND RECOMMEND APPROVAL OF LOSEE CAMPUS FIELD RENOVATIONS (FOR POSSIBLE ACTION)
  4. **ANNOUNCEMENTS AND NOTIFICATIONS**
  5. **PUBLIC COMMENT** *(NO ACTION MAY BE TAKEN ON A MATTER UNDER THIS TIME OF THE AGENDA UNTIL THE MATTER ITSELF HAS BEEN SPECIFICALLY INCLUDED ON AN AGENDA AS AN ITEM UPON WHICH ACTION WILL BE TAKEN.)*



## 6. ADJOURN MEETING

THIS NOTICE AND AGENDA HAVE BEEN POSTED ON OR BEFORE 9 A.M. ON THE THIRD WORKING DAY BEFORE THE MEETING AT THE FOLLOWING LOCATIONS:

- 1) SOMERSET ALIANTE CAMPUS – 6475 VALLEY DR., NORTH LAS VEGAS, NV 89084
- 2) SOMERSET LONE MOUNTAIN CAMPUS – 4491 N. RAINBOW BLVD., LAS VEGAS, NV 89108
- 3) SOMERSET LOSEE CAMPUS – 4650 LOSEE ROAD, NORTH LAS VEGAS, NV 89081
- 4) SOMERSET NORTH LAS VEGAS CAMPUS – 385 W. CENTENNIAL PKWY, NORTH LAS VEGAS, NV 89084
- 5) SOMERSET SKY POINTE CAMPUS – 7038 SKY POINTE DR., LAS VEGAS, NV 89131
- 6) SOMERSET SKYE CANYON CAMPUS – 8151 N. SHAUMBER ROAD, LAS VEGAS, NV 89166
- 7) SOMERSET STEPHANIE CAMPUS – 50 N. STEPHANIE ST., HENDERSON, NV 89074
- 8) [HTTPS://SOMERSETACADEMYOFLASVEGAS.COM/](https://somersetacademyoflasvegas.com/)
- 9) [HTTPS://NOTICE.NV.GOV/](https://notice.nv.gov/)

**SOMERSET ACADEMY OF LAS VEGAS  
FINANCE COMMITTEE  
SUPPORT SUMMARY**

MEETING DATE: **FEBRUARY 2, 2024**  
AGENDA ITEM: **3a – REVIEW AND APPROVAL OF THE MINUTES FROM THE OCTOBER 20, 2023 FINANCE COMMITTEE MEETING**  
NUMBER OF ENCLOSURES: **1**

**SUBJECT: APPROVAL OF MINUTES**

ACTION  
 CONSENT AGENDA  
 INFORMATION  
 PUBLIC HEARING

**PRESENTER(S): COMMITTEE**

PROPOSED WORDING FOR MOTION/ACTION:

**MOVE TO APPROVE THE MINUTES FROM THE OCTOBER 20, 2023 FINANCE COMMITTEE MEETING.**

FISCAL IMPACT: **NO**

ESTIMATED LENGTH OF TIME FOR CONSIDERATION (IN MINUTES): **2 MINUTES**

BACKGROUND:

**MINUTES FROM THE OCTOBER 20, 2023 FINANCE COMMITTEE MEETING SHOULD BE REVIEWED BY THE COMMITTEE FOR POSSIBLE APPROVAL.**

**MINUTES**  
**of the meeting of the**  
**SOMERSET ACADEMY OF LAS VEGAS FINANCE COMMITTEE**  
**October 20, 2023**

Somerset Academy of Nevada Finance Committee held a public meeting on April 28, 2023, at 11:45 p.m. via Zoom meeting.

**1. CALL TO ORDER AND ROLL CALL**

Committee member John Bentham called the meeting to order at 11:50 a.m. In attendance were Committee Members Will Harty, Jill Dayne, and John Bentham.

Also present were Principal Lee Esplin, Principal Mindi Palomeque, Principal Kaye Lackey, Principal Shannon Manning, Principal David Fossett, Principal Cesar Tiu, and Somerset system office manager Renee Kohley. Academica representatives Gary McClain and Sheri Cooper were also in attendance.

**2. PUBLIC COMMENT**

There was no public comment.

**3. ACTION & DISCUSSION ITEMS**

**a. REVIEW AND APPROVAL OF THE MINUTES FROM THE APRIL 28, 2023 FINANCE COMMITTEE MEETING**

**MEMBER HARTY MOVED TO APPROVE THE MINUTES FROM THE APRIL 28, 2023 FINANCE COMMITTEE MEETING. MEMBER BENTHAM SECONDED THE MOTION, AND THE COMMITTEE VOTED UNANIMOUSLY TO APPROVE.**

**b. REVIEW AND DISCUSSION OF SOMERSET ACADEMY FINANCIAL PERFORMANCE**

Ms. Sheri Cooper addressed the Committee and presented the financial performance for fiscal year 2023, as contained in the support materials. She reviewed the financial framework and other key financial information. She highlighted various financial metrics, including the current ratio, which ended the year at 5.46, slightly down from the prior year but meeting the metric requirement of 1.1. The unrestricted days cash on hand increased to 202 days compared to the previous year's 182 days, and the enrollment forecast accuracy was at 96.10%, slightly lower than the prior year but still meeting metrics above 95%. There were no debt defaults, but there was an error in the total margin calculation (10.79%) due to interest expense not being in the original calculation. The corrected net surplus was \$3,529,348 resulting in a total margin of 4.5%. Ms. Cooper noted that the three-year margin also decreased to 7.59.

Ms. Cooper stated that the debt-to-asset ratio decreased slightly to 62.92, which far exceeded the metric. Member Harty asked for clarification on the net surplus and asked if depreciation was used when calculating the net surplus, to which Ms. Cooper replied in the negative. Ms. Cooper stated that the Average Daily Enrollment (ADE) looked good for all of the campuses. She reviewed the income statement noting that the overall variance was very good. She explained that some expenses, including textbooks and technology, were incurred in fiscal year 23 due to the timing of the vendor invoices even though they had been approved for fiscal year 24.

Ms. Cooper reviewed several categories, including professional services (which included labor for a tech refresh, Raising the Bar, and the Academica fee), substitute services, utilities, and copier fees. The interest income and expense were included at the bottom of the income statement. Member Harty asked for clarification on the \$3.7 budget-to-actual variance. Ms. Cooper explained that the interest income was added to the variance and the interest expense was subtracted. Member Harty confirmed that the three-year total surplus was \$18 million.

**c. REVIEW AND RECOMMEND APPROVAL TO ENGAGE BOB GRONAUER’S OFFICE FOR LAND USE FOR LONE MOUNTAIN AND SKY POINTE EXPANSIONS**

Mr. McClain addressed the Committee and explained that he had not received the engagement letter from Bob Gronauer’s office. This item would be included as an action item on the October 30<sup>th</sup> board meeting agenda.

**THIS ITEM WAS TABLED.**

**d. REVIEW OF LIST OF PROJECTS**

Mr. McClain presented a list of projects that would require the Board of Director’s approval. He noted that discussing the project was challenging due to the pending completion of the surplus spending plan and reserve study. He suggested a more in-depth discussion take place during a strategic planning meeting. Discussion ensued regarding the previous delay of projects and the appropriate procedure moving forward. It was determined to add the discussion to the upcoming board meeting to aid in the decision-making process.

**e. UPDATE ON SURPLUS SPENDING PLAN**

Mr. McClain stated that Complex Solutions was working on the reserve spending study, which would be presented to the board at a future meeting.

**4. ANNOUNCEMENTS AND NOTIFICATIONS**

Principal

**5. MEMBER COMMENT**

There was not member comment.

**6. PUBLIC COMMENT**

There was no public comment

**7. ADJOURN MEETING**

**THE MEETING WAS ADJOURNED AT 12:28 P.M.**

**Approved on:**

---

**of the Finance Committee of  
Somerset Academy of Las Vegas**

**SOMERSET ACADEMY OF LAS VEGAS  
FINANCE COMMITTEE  
SUPPORT SUMMARY**

MEETING DATE: **FEBRUARY 2, 2024**  
AGENDA ITEM: **3b – REVIEW AND DISCUSSION OF SOMERSET FINANCIAL PERFORMANCE**  
NUMBER OF ENCLOSURES: **1**

**SUBJECT: FINANCIAL PERFORMANCE**

ACTION  
 CONSENT AGENDA  
 INFORMATION  
 PUBLIC HEARING

**PRESENTER(S): SHERI COOPER**

PROPOSED WORDING FOR MOTION/ACTION:

**FISCAL IMPACT: NO**

**ESTIMATED LENGTH OF TIME FOR CONSIDERATION (IN MINUTES): 10-15 MINUTES**

BACKGROUND:

**REVIEW OF FINANCIAL REVIEW SUMMARY, BALANCE SHEET, AND PROFIT AND LOSS STATEMENTS.**

# Somerset Academy of Las Vegas

## Financial Update

November 2023



ACADEMICA



## Nevada SPCSA Financial Framework (w/ projections)

### Current Year

Current Ratio	
Current Assets	63,104,259
Current Liabilities	16,314,155
<b>Current Ratio</b>	<b>3.87</b>

Unrestricted Days Cash on Hand	
Unrestricted Cash	36,638,523
Total Expenses (including grants)	92,728,212
Less: Depreciation	3,361,460
Total Cash Expenses	89,366,752
Total Cash Expenses / 365	244,840
<b>Unrestricted Days Cash</b>	<b>149.64</b>

Enrollment Forecast Accuracy	
Actual Avg ADE Enrollment	9,367
Projected Enrollment	9,380
<b>Forecast Accuracy</b>	<b>99.87%</b>

Debt Default	
Debt Default	No
Facility Lease Default	No

Total Margin	
Current Year Net Surplus	4,774,549
Current Year Total Revenues (including grants)	99,714,451
<b>Current Total Margin</b>	<b>4.79%</b>

Total Margin 3 Year	
Surplus Over Last 3 Years	12,432,538
Total Revenues Over Last 3 Years	269,967,481
<b>Current Total Margin</b>	<b>4.61%</b>

Debt to Asset Ratio	
Total Debt (Less: PERS)	130,062,195
Total Assets	178,983,972
<b>Debt to Asset Ratio</b>	<b>72.67%</b>

Cash Flow (including Restricted Cash)	
CY Unrestricted Cash	36,638,523
CY Restrictd Cash	18,445,620
CY Total Cash	55,084,144
PY Total Cash	54,931,401
<b>Cash Increase (Decrease)</b>	<b>152,743</b>

### Prior Year

Current Ratio	
Current Assets	57,020,280
Current Liabilities	10,446,224
<b>Current Ratio</b>	<b>5.46</b>

Unrestricted Days Cash on Hand	
Unrestricted Cash	38,491,726
Total Expenses (including grants)	77,567,180
Less: Depreciation	3,361,460
Total Cash Expenses	74,205,720
Total Cash Expenses / 365	203,303
<b>Unrestricted Days Cash</b>	<b>189.33</b>

Enrollment Forecast Accuracy	
Actual Avg ADE Enrollment	9,442
Projected Enrollment	9,825
<b>Forecast Accuracy</b>	<b>96.10%</b>

Debt Default	
Debt Default	No
Facility Lease Default	No

Total Margin	
Current Year Net Surplus	3,529,348
Current Year Total Revenues (including grants)	77,735,068
<b>Current Total Margin</b>	<b>4.54%</b>

Total Margin 3 Year	
Surplus Over Last 3 Years	16,437,863
Total Revenues Over Last 3 Years	249,870,905
<b>Current Total Margin</b>	<b>6.58%</b>

Debt to Asset Ratio	
Total Debt (Less: PERS)	130,062,195
Total Assets	173,110,542
<b>Debt to Asset Ratio</b>	<b>75.13%</b>

Cash Flow (including Restricted Cash)	
CY Unrestricted Cash	38,491,726
CY Restrictd Cash	16,439,675
CY Total Cash	54,931,401
PY Total Cash	49,171,058
<b>Cash Increase (Decrease)</b>	<b>5,760,343</b>

## Other Key Financial Information

### Average Daily Enrollment

Somerset System	
Projected	9,380.00
Q1	9,324.38
Q2	9,410.50
Q3	-
Q4	-
<b>Avg ADE</b>	<b>9,367.44</b>
ADE to Projected	99.87%

Aliante	
Projected	1,145.00
Q1	1,136.11
Q2	1,156.35
Q3	
Q4	
<b>Avg ADE</b>	<b>1,146.23</b>
ADE to Projected	100.11%

Lone Mountain	
Projected	986.00
Q1	986.41
Q2	992.35
Q3	
Q4	
<b>Avg ADE</b>	<b>989.38</b>
ADE to Projected	100.34%

Losee	
Projected	2,380.00
Q1	2,360.38
Q2	2,400.64
Q3	
Q4	
<b>Avg ADE</b>	<b>2,380.51</b>
ADE to Projected	100.02%

North Las Vegas	
Projected	771.00
Q1	746.76
Q2	770.08
Q3	
Q4	
<b>Avg ADE</b>	<b>758.42</b>
ADE to Projected	98.37%

Sky Pointe	
Projected	2,145.00
Q1	2,141.32
Q2	2,149.10
Q3	
Q4	
<b>Avg ADE</b>	<b>2,145.21</b>
ADE to Projected	100.01%

Skye Canyon	
Projected	994.00
Q1	994.08
Q2	995.67
Q3	
Q4	
<b>Avg ADE</b>	<b>994.88</b>
ADE to Projected	100.09%

Stephanie	
Projected	959.00
Q1	959.32
Q2	946.31
Q3	
Q4	
<b>Avg ADE</b>	<b>952.82</b>
ADE to Projected	99.36%

## Other Key Financial Information

23-24 FY Grants Submitted through June 2024

Grant Name	Date of Submission	Amount	Date Received
SPED (IDEA, Part B) - 84.027	8/15/2023	\$ 57,821.77	8/22/2023
School Based Mental Health - 84.425D	8/1/2023	\$ 19,924.20	8/25/2023
SPED (IDEA, Part B) - 84.027	9/11/2023	\$ 49,873.74	9/29/2023
SPED EXN (IDEA, Part B) -84.027	9/12/2023	\$ 648.69	9/29/2023
SPED EXN (IDEA, Part B) -84.027	9/11/2023	\$ 2,696.17	9/26/2023
Project Aware - 94.243	9/11/2023	\$ 1,169.22	9/29/2023
Title IVA - 84.424A	9/11/2023	\$ 8,857.85	9/27/2023
School Based Mental Health - 84.425D	9/1/2023	\$ 30,281.06	9/22/2023
CTE Allocation	9/1/2023	\$ 10,337.82	9/6/2023
Title I -84.010	9/11/2023	\$ 71,562.42	9/26/2023
ESSER II - 84.425	9/11/2023	\$ 293,924.20	9/28/2023
Title II -84.367	9/12/2023	\$ 105,180.55	9/26/2023
Title II -84.367	9/11/2023	\$ 13,011.09	10/2/2023
SPED (IDEA, Part B) - 84.027	9/11/2023	\$ 86,228.63	9/26/2023
SPED ESY (IDEA, Part B) -84.027	9/11/2023	\$ 4,175.12	9/26/2023
Title I -84.010	10/12/2023	\$ 110,294.31	10/31/2023
School Based Mental Health - 84.425D	10/2/2023	\$ 4,199.51	10/11/2023
CTE Allocation	10/2/2023	\$ 10,337.82	10/11/2023
ESSER II - 84.425	10/12/2023	\$ 94,582.92	11/3/2023
SPED EXN (IDEA, Part B) -84.027	10/13/2023	\$ 7,341.97	11/6/2023
SPED EXN (IDEA, Part B) -84.027	10/11/2023	\$ 2,360.93	10/16/2023
SPED (IDEA, Part B) - 84.027	10/11/2023	\$ 23,101.29	10/13/2023
Title II -84.367	10/10/2023	\$ 28,006.24	11/3/2023
Project Aware - 94.243	10/9/2023	\$ 7,496.00	10/11/2023
Title IVA - 84.424A	10/9/2023	\$ 5,683.39	10/20/2023
Title II -84.367	10/9/2023	\$ 18,596.00	10/11/2023
SPED (IDEA, Part B) - 84.027	10/9/2023	\$ 106,769.03	10/12/2023
School Based Mental Health - 84.425D	11/9/2023	\$ 44,171.04	
CTE Allocation	11/9/2023	\$ 10,337.82	11/15/2023
SPED EXN (IDEA, Part B) -84.027	11/14/2023	\$ 3,796.26	11/23/2023
AB495 - 21.027	11/14/2023	\$ 286,243.27	11/23/2023
ARP ESSER III 2/3 - 84.425 U	11/30/2023	\$ 257,659.60	
ARP ESSER III Final 1/3 - 84.425U	11/30/2023	\$ 223,171.31	12/18/2023

**Academica Nevada**  
**Somerset Academy of Las Vegas**  
**Budget vs. Actual - Board Setup**  
**From Jul 2023 to Nov 2023**

	<b>Actual</b>	<b>Budget</b>	<b>Variance</b>
<b>Income</b>			
Distributive School Account (DSA)	34,832,744	84,101,080	(49,268,336)
English Learners	574,939	1,379,628	(804,689)
At-Risk Pupil	394,873	947,695	(552,822)
Gifted and Talented	50,658	121,475	(70,818)
Special Education	3,335,657	8,829,439	(5,493,782)
NSLP	1,437,280	3,966,125	(2,528,845)
Other	-	-	-
<b>Total - Income</b>	<b>40,626,150</b>	<b>99,345,442</b>	<b>(58,719,292)</b>
<b>Expense</b>			
Salaries	18,864,309	37,859,102	18,994,793
Bonus	2,431,729	2,586,625	154,896
SPED Salaries	780,899	6,250,872	5,469,973
Retirement Contributions (PERS)	4,620,005	14,762,375	10,142,370
<b>Total Salaries and Bonus</b>	<b>26,696,942</b>	<b>61,458,974</b>	<b>34,762,032</b>
Employee Taxes and Benefits	2,547,151	5,998,400	3,451,249
<b>Total Salaries and Benefits</b>	<b>29,244,093</b>	<b>67,457,374</b>	<b>38,213,281</b>
Tuition Reimbursement	23,894	127,000	103,107
Training and Development	41,715	70,500	28,785
Affiliation Fee Training	33,890	420,505	386,615
Consumables/ Textbooks/ Tech / Equip	1,644,293	2,144,090	499,797
Supplies and Materials	467,900	1,266,540	798,640
SPED Supplies	27,025	178,650	151,625
SPED - Contracted Services	554,289	1,756,170	1,201,881
Substitute Services	396,549	645,363	248,814
Extra Curricular	94,490	229,000	134,510
Affiliation Fee Inc	267,134	420,505	153,371
Professional Services	2,247,251	5,764,188	3,516,937
State Administrative Fee	435,409	1,081,873	646,464
Operations	415,706	2,207,475	1,791,769
Food Expenditures	937,034	3,538,845	2,601,811
Building Operations and Maintenance	4,526,276	11,697,553	7,171,277
Utilities	756,999	1,920,700	1,163,701
<b>Total - Expense</b>	<b>42,113,945</b>	<b>100,926,331</b>	<b>58,812,386</b>
<b>Other Income and Expenses</b>			
Interest Income	921,538	1,773,000	(851,462)
Bond Issuance Cost	-	-	-
Interest Expense	-	-	-
Misc	-	-	-
Foundation Interest Expense	-	-	-
Foundation Depreciation Expense	-	-	-
<b>Net Income</b>	<b>(566,257)</b>	<b>192,111</b>	<b>(758,368)</b>

### **Consumables**

- 62481 - Summer Purchases- Furniture and Fixtures
- 62551 - Summer Purchases - Software
- 62561 - Summer Purchases - Computers
- 62613 - Summer Purchases - Supplies
- 62643 - Summer Purchases - Textbooks

### **Supplies**

- 62480 - Supplies/Equipment - Non-Tech Furniture and Fixtures
  - 62610 - General Supplies
  - 62611 - Copier Supplies
  - 62612 - Custodial Supplies
- 62614 - Assessment and Testing Materials
  - 62617 - Office Supplies
  - 62618 - Nurse Supplies
- 62619 - Classroom Supplies

### **Professional Services**

- 63124 - Legal Fee
- 63125 - Audit and Tax Services
- 63126 - Management Fee
- 63127 - Background/Drug Tests
- 63160 - Purchased Professional and Technical Services
  - 63200 - Technical Services
  - 63210 - Other Technical Services
- 63310 - Official/Administrative Services
  - 63311 - Payroll Service Fees
- 64250 - Technology Software
- 64260 - Technology-Related Repairs and Maintenance

### **Utilities**

- 65510 - Electricity
- 65520 - Energy
- 65530 - Natural Gas
- 65540 - Water/Sewage
- 65550 - Garbage / Disposal

### **Building Operations and Maintenance**

- 63631 - Alarm Services
- 63632 - Fire Services
- 65100 - Janitorial / Custodial Services
- 65101 - Janitorial Additional Services
- 65110 - Non Janitorial Cleaning Services
  - 65111 - Lawn Care
  - 65112 - Snow Removal
- 63630 - Other Purchased Property Services
- 65310 - Repairs and Maintenance Svcs
- 65311 - A/C Repairs and Maintenance
- 65400 - Rental of Land and Buildings

### **Food Expenditures**

- 64100 - Food Service Management
- 64110 - Food Expenditures

### **Operations**

- 62400 - Printing and Binding
- 63220 - Telecommunications
- 63230 - Communications
  - 63231 - Internet
- 63240 - Data Communications, Internet, Video, T-lines, web-based pro
  - 63320 - Advertising
  - 63330 - Marketing Services
  - 63340 - Delivery Services / Couriers
  - 63350 - Postage
- 63400 - Student Transportation Services
  - 63610 - Dues and Fees
- 64270 - Rentals of Computers and Related Equipment
  - 64271 - Copier Fees Monthly
  - 64272 - Copier Fees Overage
- 65200 - Insurance (Other Than Employee Benefits)
  - 65210 - Liability Insurance
  - 65220 - Property Insurance

**SOMERSET ACADEMY OF LAS VEGAS  
FINANCE COMMITTEE  
SUPPORT SUMMARY**

MEETING DATE: **FEBRUARY 2, 2024**  
AGENDA ITEM: **3c – REVIEW AND RECOMMEND APPROVAL OF 2022/2023 SINGLE AUDIT**  
NUMBER OF ENCLOSURES: **1**

**SUBJECT: 2022/2023 SINGLE AUDIT**

**ACTION**  
 **CONSENT AGENDA**  
 **INFORMATION**  
 **PUBLIC HEARING**

**PRESENTER(S): NACHUM GOLODNER/TRAVIS GOODSELL**

PROPOSED WORDING FOR MOTION/ACTION:

**MOVE TO RECOMMEND APPROVAL OF THE SINGLE AUDIT.**

FISCAL IMPACT: **NO**

ESTIMATED LENGTH OF TIME FOR CONSIDERATION (IN MINUTES): **10-15 MINUTES**

BACKGROUND:

**THE COMMITTEE WILL REVIEW AND POSSIBLY RECOMMEND APPROVAL OF THE 2022/2023 SINGLE AUDIT.**

---

**SOMERSET ACADEMY OF LAS VEGAS**

*SINGLE AUDIT REPORT*

*JUNE 30, 2023*

---

## Contents

---

	Page
Independent Auditors' Report On Internal Control Over Financial Reporting And On Compliance And Other Matters Based On An Audit Of Financial Statements Performed In Accordance With <i>Government Auditing Standards</i> .....	1 - 2
Independent Auditors' Report On Compliance For Each Major Federal Program; Report On Internal Control Over Compliance; And Report On The Schedule Of Expenditures Of Federal Awards Required By The Uniform Guidance.....	3 - 6
Schedule Of Expenditures Of Federal Awards .....	7
Notes To Schedule Of Expenditures Of Federal Awards .....	8
Schedule Of Findings And Questioned Costs .....	9 - 13
Summary Schedule Of Prior Audit Findings.....	14 - 15
Corrective Action Plan .....	16 - 17



**Independent Auditors' Report  
On Internal Control Over Financial  
Reporting And On Compliance And Other  
Matters Based On An Audit Of Financial  
Statements Performed In Accordance With  
*Government Auditing Standards***

Board of Directors  
Somerset Academy of Las Vegas  
Las Vegas, Nevada

We have audited, in accordance with the auditing standards generally accepted in the United States of America and the standards applicable to financial audits contained in *Government Auditing Standards*, issued by the Comptroller General of the United States, the financial statements of the governmental activities and each major fund of Somerset Academy of Las Vegas, as of and for the year ended June 30, 2023, and the related notes to the financial statements, which collectively comprise Somerset Academy of Las Vegas's basic financial statements, and have issued our report thereon dated November 30, 2023.

**Report On Internal Control Over Financial Reporting**

In planning and performing our audit of the financial statements, we considered Somerset Academy of Las Vegas's internal control over financial reporting (internal control) as a basis for designing audit procedures that are appropriate in the circumstances for the purpose of expressing our opinions on the financial statements, but not for the purpose of expressing an opinion on the effectiveness of Somerset Academy of Las Vegas's internal control. Accordingly, we do not express an opinion on the effectiveness of Somerset Academy of Las Vegas's internal control.

Our consideration of internal control was for the limited purpose described in the preceding paragraph and was not designed to identify all deficiencies in internal control that might be material weaknesses or significant deficiencies and therefore, material weaknesses or significant deficiencies may exist that were not identified. However, as described in the accompanying Schedule of Findings as Responses, we identified certain deficiencies in internal control, that we consider to be material weaknesses and significant deficiencies.

*A deficiency in internal control* exists when the design or operation of a control does not allow management or employees, in the normal course of performing their assigned functions, to prevent, or detect and correct, misstatements on a timely basis. A *material weakness* is a deficiency, or a combination of deficiencies, in internal control such that there is a reasonable possibility that a material misstatement of the entity's financial statements will not be prevented, or detected and corrected, on a timely basis. We consider the deficiencies described in the accompanying Schedule of Findings and Responses as items 2023-001 and 2023-002 to be material weaknesses.

A *significant deficiency* is a deficiency, or a combination of deficiencies, in internal control that is less severe than a material weakness, yet important enough to merit attention by those charged with governance. We consider the deficiencies described in the accompanying Schedule of Findings and Responses as items 2023-003 and 2023-004 to be significant deficiencies.

### **Report On Compliance And Other Matters**

As part of obtaining reasonable assurance about whether Somerset Academy of Las Vegas's financial statements are free from material misstatement, we performed tests of its compliance with certain provisions of laws, regulations, contracts, and grant agreements, noncompliance with which could have a direct and material effect on the financial statements. However, providing an opinion on compliance with those provisions was not an objective of our audit, and accordingly, we do not express such an opinion. The results of our tests disclosed no instances of noncompliance or other matters that are required to be reported under *Government Auditing Standards*.

### **School's Response To Findings**

*Government Auditing Standards* requires the auditor to perform limited procedures on Somerset Academy of Las Vegas's response to the findings identified in our audit and described in the accompanying schedule of findings and questioned costs. The Somerset Academy of Las Vegas's response was not subjected to the other auditing procedures applied in the audit of the financial statements and accordingly, we express no opinion on the response.

### **Purpose Of This Report**

The purpose of this report is solely to describe the scope of our testing of internal control and compliance and the results of that testing, and not to provide an opinion on the effectiveness of Somerset Academy of Las Vegas's internal control or on compliance. This report is an integral part of an audit performed in accordance with *Government Auditing Standards* in considering Somerset Academy of Las Vegas's internal control and compliance. Accordingly, this communication is not suitable for any other purpose.

*RubinBrown LLP*

January 11, 2024

**Independent Auditors' Report  
On Compliance For Each Major Federal  
Program; Report On Internal Control Over  
Compliance; And Report On The Schedule  
Of Expenditures Of Federal Awards  
Required By The Uniform Guidance**

Board of Directors  
Somerset Academy of Las Vegas  
Las Vegas, Nevada

**Report On Compliance For Each Major Federal Program**

***Opinion On Each Major Federal Program***

We have audited Somerset Academy of Las Vegas's compliance with the types of compliance requirements identified as subject to audit in the *OMB Compliance Supplement* that could have a direct and material effect on each of Somerset Academy of Las Vegas's major federal programs for the year ended June 30, 2023. Somerset Academy of Las Vegas's major federal programs are identified in the summary of auditors' results section of the accompanying schedule of findings and questioned costs.

In our opinion, Somerset Academy of Las Vegas complied, in all material respects, with the compliance requirements referred to above that could have a direct and material effect on each of its major federal programs for the year ended June 30, 2023.

***Basis For Opinion On Each Major Federal Program***

We conducted our audit of compliance in accordance with auditing standards generally accepted in the United States of America (GAAS); the standards applicable to financial audits contained in *Government Auditing Standards*, issued by the Comptroller General of the United States; and the audit requirements of Title 2 U.S. *Code of Federal Regulations* Part 200, *Uniform Administrative Requirements, Cost Principles, and Audit Requirements for Federal Awards* (Uniform Guidance). Our responsibility under those standards and the Uniform Guidance are further described in the Auditors' Responsibilities For The Audit Of Compliance section of our report.

We are required to be independent of Somerset Academy of Las Vegas and to meet our ethical responsibilities in accordance with relevant ethical requirements relating to our audit. We believe that the audit evidence we have obtained is sufficient and appropriate to provide a basis for our opinion on compliance for each major federal program. Our audit does not provide a legal determination of Somerset Academy of Las Vegas's compliance with the compliance requirements referred to above.

### ***Responsibilities Of Management For Compliance***

Management is responsible for compliance with the requirements referred to above and for the design, implementation, and maintenance of effective internal control over compliance with the requirements of laws, statutes, regulations, rules and provisions of contracts or grant agreements applicable to Somerset Academy of Las Vegas's federal programs.

### ***Auditors' Responsibilities For The Audit Of Compliance***

Our objectives are to obtain reasonable assurance about whether material noncompliance with the compliance requirements referred to above occurred, whether due to fraud or error, and express an opinion on Somerset Academy of Las Vegas's compliance based on our audit. Reasonable assurance is a high level of assurance but is not absolute assurance and therefore is not a guarantee that an audit conducted in accordance with GAAS, *Government Auditing Standards*, and the Uniform Guidance will always detect material noncompliance when it exists. The risk of not detecting material noncompliance resulting from fraud is higher than for that resulting from error, as fraud may involve collusion, forgery, intentional omissions, misrepresentations, or the override of internal control. Noncompliance with the compliance requirements referred to above is considered material, if there is a substantial likelihood that, individually or in the aggregate, it would influence the judgment made by a reasonable user of the report on compliance about the School's compliance with the requirements of each major federal program as a whole.

In performing an audit in accordance with GAAS, *Government Auditing Standards*, and the Uniform Guidance, we:

- Exercise professional judgment and maintain professional skepticism throughout the audit.
- Identify and assess the risks of material noncompliance, whether due to fraud or error, and design and perform audit procedures responsive to those risks. Such procedures include examining, on a test basis, evidence regarding the School's compliance with the compliance requirements referred to above and performing such other procedures as we considered necessary in the circumstances.
- Obtain an understanding of the School's internal control over compliance relevant to the audit in order to design audit procedures that are appropriate in the circumstances and to test and report on internal control over compliance in accordance with the Uniform Guidance, but not for the purpose of expressing an opinion on the effectiveness of the School's internal control over compliance. Accordingly, no such opinion is expressed.

We are required to communicate with those charged with governance regarding, among other matters, the planned scope and timing of the audit and any significant deficiencies and material weaknesses in internal control over compliance that we identified during the audit.

## **Report On Internal Control Over Compliance**

Our consideration of internal control over compliance was for the limited purpose described in the Auditors' Responsibilities For The Audit Of Compliance section above and was not designed to identify all deficiencies in internal control over compliance that might be material weaknesses or significant deficiencies in internal control over compliance and therefore, material weaknesses or significant deficiencies may exist that were not identified. We did not identify any deficiencies in internal control over compliance that we consider to be material weaknesses. However, as discussed below, we did identify a deficiency in internal control over compliance that we consider to be a significant deficiency.

*A deficiency in internal control over compliance* exists when the design or operation of a control over compliance does not allow management or employees, in the normal course of performing their assigned functions, to prevent, or detect and correct, noncompliance with a type of compliance requirement of a federal program on a timely basis. *A material weakness in internal control over compliance* is a deficiency, or a combination of deficiencies, in internal control over compliance, such that there is a reasonable possibility that material noncompliance with a type of compliance requirement of a federal program will not be prevented, or detected and corrected, on a timely basis. *A significant deficiency in internal control over compliance* is a deficiency, or a combination of deficiencies, in internal control over compliance with a type of compliance requirement of a federal program that is less severe than a material weakness in internal control over compliance, yet important enough to merit attention by those charged with governance. We consider the deficiency in internal control over compliance described in the accompanying schedule of findings and questioned costs as item 2023-005 to be a significant deficiency.

Our audit was not designed for the purpose of expressing an opinion on the effectiveness of internal control over compliance. Accordingly, no such opinion is expressed.

*Government Auditing Standards* requires the auditor to perform limited procedures on Somerset Academy of Las Vegas's response to the internal control over compliance findings identified in our audit described in the accompanying schedule of findings and questioned costs. Somerset Academy of Las Vegas's response was not subjected to the auditing procedures applied in the audit of compliance, and accordingly, we express no opinion on the responses.

The purpose of this report on internal control over compliance is solely to describe the scope of our testing of internal control over compliance and the results of that testing based on the requirements of the Uniform Guidance. Accordingly, this report is not suitable for any other purpose.

## **Report On Schedule Of Expenditures Of Federal Awards Required By The Uniform Guidance**

We have audited the financial statements of the governmental activities and each major fund of Somerset Academy of Las Vegas as of and for the year ended June 30, 2023, and the related notes to the financial statements, which collectively comprise Somerset Academy of Las Vegas's basic financial statements. We have issued our report thereon dated November 30, 2023, which contained unmodified opinions on those financial statements. Our audit was conducted for the purpose of forming opinions on the financial statements that collectively comprise the basic financial statements. The accompanying schedule of expenditures of federal awards is presented for purposes of additional analysis as required by the Uniform Guidance and is not a required part of the basic financial statements. Such information is the responsibility of management and was derived from and relates directly to the underlying accounting and other records used to prepare the basic financial statements. The information has been subjected to the auditing procedures applied in the audit of the financial statements and certain additional procedures, including comparing and reconciling such information directly to the underlying accounting and other records used to prepare the financial statements or to the basic financial statements themselves, and other additional procedures in accordance with auditing standards generally accepted in the United States of America. In our opinion, the schedule of expenditures of federal awards is fairly stated in all material respects in relation to the basic financial statements as a whole.

*RubinBrown LLP*

January 11, 2024

# SOMERSET ACADEMY OF LAS VEGAS

## SCHEDULE OF EXPENDITURES OF FEDERAL AWARDS For The Year Ended June 30, 2023

Federal Grantor/Pass-Through Grantor/Program Title	Federal Assistance Listing Number	Subaward/ Cluster	Pass-Through Entity Identifying Number/ Contract Number	Federal Expenditures	Expenditures To Sub-Recipients
<b>U.S. Department of Agriculture</b>					
Pass-through programs from State of Nevada Department of Agriculture:					
Child Nutrition Cluster:					
National School Lunch Program	10.555		N-23-14	\$ 1,128,468	\$ —
School Breakfast Program	10.553		N-23-14	8,110	—
<b>Total Child Nutrition Cluster</b>				1,136,578	—
Food Distribution Cluster:					
DOD Commodity Supplemental Food Program	10.565			134,029	—
<b>Total U.S. Department of Agriculture</b>				1,270,607	—
<b>U.S. Department of Treasury</b>					
Pass-through programs from State of Nevada Department of Agriculture:					
COVID-19 American Rescue Plan Act (ARPA) - Breakfast and Lunch	21.027		N-23-14	1,376,604	—
<b>Federal Communications Commission</b>					
Emergency Connectivity Fund (EFC)	32.009			690,000	—
<b>U.S. Department of Education</b>					
Pass-through programs from Nevada Department of Education:					
COVID-19 Elementary and Secondary School Emergency Relief Fund (ESSER)	84.425D	S1		300,663	—
Passed-through from State Public Charter School Authority:					
Title I Grants to Local Educational Agencies	84.010			596,899	—
McKinney-Vento Homeless Assistance	84.196A			5,000	—
Title II - Supporting Effective Instruction State Grants	84.367			554,899	—
Title IVA - Student Support and Academic Enrichment Program	84.424A			49,566	—
COVID-19 Elementary and Secondary School Emergency Relief Fund (ESSER ID)	84.425D	S1		1,927,084	—
COVID-19 American Rescue Plan - Elementary and Secondary School Emergency Relief Fund (ESSER III)	84.425U	S1		1,369,343	—
COVID-19 American Rescue Plan - Elementary and Secondary School Emergency Relief Fund (Final One-Third Allocation)	84.425U	S1		1,190,781	—
COVID-19 American Rescue Plan - Elementary and Secondary School Emergency Relief Fund (CTE)	84.425D	S1		7,050	—
COVID-19 American Rescue Plan - Elementary and Secondary School Emergency Relief Fund (Summer & Afterschool)	84.425D	S1		17,700	—
Special Education - Grants to States (IDEA, Part B)	84.027	C1		1,439,149	—
Special Education - Grants to States (IDEA, Part B EXN)	84.027	C1		67,269	—
Special Education - Grants to States (IDEA, Part B ESY)	84.027	C1		15,083	—
COVID-19 American Rescue Plan Funds - IDEA - Part B	84.027	C1		124,488	—
<b>Total passed-through from State Public Charter School Authority</b>				7,364,311	—
<b>Total U.S. Department of Education</b>				7,364,311	—
<b>Total Expenditures Of Federal Awards</b>				\$ 11,002,185	\$ —

Subawards (S) and Clusters (C)	Total
S1-Education Stabilization Fund	\$ 4,812,621
C1-Special Education Cluster (IDEA)	\$ 1,645,989

# SOMERSET ACADEMY OF LAS VEGAS

---

## NOTES TO SCHEDULE OF EXPENDITURES OF FEDERAL AWARDS

June 30, 2023

### 1. General

The accompanying Schedule of Expenditures of Federal Awards (the Schedule) presents the activity of all federal award programs of Somerset Academy of Las Vegas. The information in this Schedule is presented in accordance with the requirements of Title 2 U.S. Code of Federal Regulations Part 200, *Uniform Administrative Requirements, Cost Principles, and Audit Requirements for Federal Awards* (Uniform Guidance). Therefore, some amounts presented in the Schedule may differ from amounts presented in, or used in the preparation of, the financial statements and it is not intended to and does not present the net position, changes in net position or cash flows of Somerset Academy of Las Vegas.

Pass-through entity identifying numbers are presented where available.

### 2. Basis Of Accounting

The accompanying schedule of expenditures of federal awards is presented using the accrual basis of accounting, which is described in Note 1 to the financial statements of Somerset Academy of Las Vegas.

### 3. Indirect Costs

Somerset Academy of Las Vegas has not elected to use the 10% de minimis indirect cost rate as allowed in the Uniform Guidance, Section 414.



**SOMERSET ACADEMY OF LAS VEGAS**  
**SCHEDULE OF FINDINGS AND QUESTIONED COSTS**  
**For The Year Ended June 30, 2023**

**Section I - Summary Of Auditors' Results**

**Financial Statements**

Type of report the auditor issued on whether the financial statements audited were prepared in accordance with accounting principles generally accepted in the United States of America:

Unmodified

Internal control over financial reporting:

- Material weakness(es) identified?  yes  no
- Significant deficiency(ies) identified?  yes  none reported

Noncompliance material to financial statements noted?

yes  no

**Federal Awards**

Internal control over major federal programs:

- Material weakness(es) identified?  yes  no
- Significant deficiency(ies) identified?  yes  none reported

Type of auditors' report issued on compliance for major federal programs:

Unmodified

Any audit findings disclosed that are required to be reported in accordance with 2 CFR 200.516(a)?

yes  no

Identification of major federal programs:

<u>Name Of Federal Program Or Cluster</u>	<u>Federal Assistance Listing Number</u>
Child Nutrition Cluster	
National School Lunch Program	10.555
School Breakfast Program	10.553
American Rescue Plan Act (ARPA) - Breakfast and Lunch	21.027
Special Education Cluster (IDEA, Part B)	84.027
Education Stabilization Fund	84.425
Subawards	
Elementary and Secondary School Emergency Relief Fund	84.425D
American Rescue Plan-Elementary and Secondary School Emergency Relief Fund	84.425U

Dollar threshold used to distinguish between type A and type B programs:

\$ 750,000

Auditee qualified as low-risk auditee?

yes  no

---

# SOMERSET ACADEMY OF LAS VEGAS

---

## SCHEDULE OF FINDINGS AND QUESTIONED COSTS *(Continued)* For The Year Ended June 30, 2023

---

### Section II - Financial Statement Findings

---

#### **2023 -001 Revenue Recognition and Accounts Receivable Aging – Material Weakness**

**Criteria:** Management is responsible for establishing and maintaining an effective system of internal control over financial reporting. Processes and procedures should include a review and reconciliation of year-end accounts.

**Condition:** During the course of the audit, the engagement team identified an error in revenues that were accrued in the prior year in accounts receivable and when the funds were collected in the current year, revenues were recorded rather than applying the payment against the receivable. The old outstanding receivables on the aging were not researched as to the status of the receivable.

**Cause:** The review process did not include researching old reconciling items.

**Effect:** Prior to adjustment, accounts receivable and revenues were overstated by \$1,375,824.

**Auditors' Recommendation:** We recommend the School enhance internal controls to ensure appropriate revenue recognition in accordance with established policies and U.S. GAAP and to ensure the review process of accounts receivable includes investigating outstanding receivables in excess of sixty days, or the average collection period for a particular grant.

**View of Responsible Officials and Timing:** The error was missed due to the later than expected start of year end reconciliation review process caused by delayed 2022 single audits and financial audits. Management is doing a review of current staffing with the goal of increasing staff to ensure a timely and efficient year-end process.

#### **2023 -002 Reconciliation of Accounts - Material Weakness**

**Criteria:** The School should have a process in place to provide consistent support of the timely preparation of account reconciliations to include evidence of the overall review and approval.

**Condition:** During the course of the audit, the engagement team identified instances of accrued payroll being understated for the last pay period of the fiscal year, prepaid expenses were overstated, and bond amortization being recorded backwards.

**Cause:** The School does not have an appropriate process in place to provide consistent support of the review and approval of accrued payroll and comparison of schedules to the adjusted trial balance to verify adjustments were properly posted.

## SOMERSET ACADEMY OF LAS VEGAS

---

### SCHEDULE OF FINDINGS AND QUESTIONED COSTS *(Continued)* For The Year Ended June 30, 2023

**Auditors' Recommendation:** We recommend that the School develop a consistent process to reconcile and review accrued payroll and compare the trial balance to supporting schedules during the month end and year end closing processes for accuracy.

**View of Responsible Officials and Timing:** The under accrual of payroll was caused by teachers and other employees having different contract terms. After a thorough review of contracts, management agrees with the finding, and will ensure to include all employees in future accruals in accordance with contract terms. The error in bond amortization was missed due to the later than expected start of year end reconciliation review process caused by delayed 2022 single audits and financial audits. Management is doing a review of current staffing with the goal of increasing staff to ensure a timely and efficient year-end process.

#### **2023 -003 Understatement of Bond Accrued Interest – Significant Deficiency**

**Criteria:** The School should have a process in place to review bond accrual calculations to ensure that appropriate adjustments are made.

**Condition:** During the course of the audit, the engagement team identified that bond accrued interest was not calculated from the last payment of interest on June 15th through the end of the fiscal year.

**Cause:** The School does not have an appropriate process in place to review bond accrual calculations and ensure that they are calculated for the full period from the last payment of the year through the end of the fiscal year.

**Effect:** Interest payable and interest expense are understated by \$250,024 for the year ended June 30, 2023.

**Auditors' Recommendation:** We recommend that the School develop a consistent process to review the calculation of bond accrued interest for fiscal year reporting.

**View of Responsible Officials and Timing:** The error was missed due to the later than expected start of year end reconciliation review process caused by delayed 2022 single audits and financial audits. Management is doing a review of current staffing with the goal of increasing staff to ensure a timely and efficient year-end process.

# SOMERSET ACADEMY OF LAS VEGAS

---

## SCHEDULE OF FINDINGS AND QUESTIONED COSTS *(Continued)* For The Year Ended June 30, 2023

### **2023 -004 Review of Capital Assets for the Removal of Fully Depreciated Items No Longer In Use - Significant Deficiency**

**Criteria:** The School should have a process in place to periodically review the fixed asset listing for assets that are no longer in use or were disposed of and for recording the disposal in the accounting software.

**Condition:** During the course of the audit, the engagement team identified multiple instances fully depreciated capital assets no longer in use or held by the School were not recorded as disposals.

**Cause:** The School does not have an appropriate process in place to review the fixed asset listing to ensure that capital assets no longer in use or owned by the School are recorded as disposals and timely removed from the fixed asset listing.

**Effect:** Prior to adjustment gross capital assets and gross accumulated depreciation and amortization were overstated by \$689,452.

**Auditors' Recommendation:** We recommend that the School develop a consistent process to review the fixed asset listing and ensure that capital assets no longer in use or owned by the School are removed and that the corresponding entries to record the disposal are posted to the accounting records.

**View of Responsible Officials and Timing:** The error was missed due to the later than expected start of year end reconciliation review process caused by delayed 2022 single audits and financial audits. Management is doing a review of current staffing with the goal of increasing staff to ensure a timely and efficient year-end process. Management will review the fixed assets ledger during the next fiscal year to ensure any items that have been disposed of have been removed from the general ledger.

---

## SOMERSET ACADEMY OF LAS VEGAS

---

### SCHEDULE OF FINDINGS AND QUESTIONED COSTS *(Continued)* For The Year Ended June 30, 2023

---

---

#### Section III - Federal Award Findings And Questioned Costs

---

#### **2023 -005 Review And Approval Of The Schedule Of Expenditures Of Federal Awards (SEFA) – Significant Deficiency**

**Criteria:** The Uniform Guidance in 2 CFR Section 200.303 requires that non-Federal entities receiving Federal awards (i.e. auditee management) establish and maintain internal control designed to reasonably ensure compliance with Federal statutes, regulations, and the terms and conditions of the Federal award. The School should have a written process in place to perform a review of the SEFA, to include evidence of the resolution of variances, as well as a process to document the overall review and approval to ensure proper presentation, completeness, and accuracy of the SEFA.

**Condition:** During the course of the audit, the engagement team noted a review process of the SEFA had been implemented during 2023. However, there was no formal written review process.

**Cause:** The entity does not have a written process in place to review the SEFA, to include retaining evidence of the resolution of variances, as well as documentation of the overall review and approval.

**Effect:** Potential misstatement could occur if expenditure amounts are not accurately presented on the SEFA.

**Questioned Costs:** Not applicable.

**Context:** Not applicable.

**Identification As A Repeat Finding:** Yes.

**Recommendation:** The School should develop a written consistent process to review the SEFA. Issues identified during the course of the review should be investigated and resolved in a timely manner.

**View Of Responsible Officials:** While there was a review of the SEFA, the documentation of said review did not occur properly. Management has put in place a process to document preparation/review of the SEFA evidenced by signature and date.

# SOMERSET ACADEMY OF LAS VEGAS

---

## SUMMARY SCHEDULE OF PRIOR AUDIT FINDINGS For The Year Ended June 30, 2023

### Financial Statement Findings

#### **2022 -001 Reconciliation of Accounts – Significant Deficiency**

**Condition:** During the course of the audit, the engagement team identified multiple instances where accurate account reconciliations were not adequately performed, to include a review of outstanding reconciling items on cash reconciliations, accounts receivable aging schedules, prepaid expense schedules and account payable aging schedules and a review of the calculation of payroll accruals.

**Status:** During 2023, the School properly reconciled cash and accounts payable aging schedules. However, there were findings related to the calculation of accrued payroll, prepaid expenses and accounts receivable which are included in findings 2023-001 and 2023-002.

#### **2022 -002 Understatement of Bond Accrued Interest – Significant Deficiency**

**Condition:** During the course of the audit, the engagement team identified that bond accrued interest was not calculated from the last payment of interest on June 15th through the end of the year.

**Status:** A similar finding was noted in 2023 and is included in finding 2023-003.

#### **2022 -003 Accounting For Lease Residual Values - Significant Deficiency**

**Condition:** During the course of the audit, the engagement team identified multiple instances where the lease liability and associated capital assets for several leases associated with the purchases of curriculum, technology and equipment did not accurately include a provision for residual values.

**Status:** There were no leases entered into during 2023 that contained residual values and no similar findings were noted in the current year.

#### **2022 -004 Review of Capital Assets for the Removal of Fully Depreciated Items No Longer In Use - Significant Deficiency**

**Condition:** During the course of the audit, the engagement team identified multiple instances fully depreciated capital assets no longer in use or held by the School were not recorded as disposals.

**Status:** A similar finding was noted in 2023 and is included in finding 2023-004.

# SOMERSET ACADEMY OF LAS VEGAS

---

## SUMMARY SCHEDULE OF PRIOR AUDIT FINDINGS *(Continued)* For The Year Ended June 30, 2023

### Federal Award Findings And Questioned Costs

#### **2022 -005 Review And Approval Of The Schedule Of Expenditures Of Federal Awards (SEFA) - Significant Deficiency**

##### **All Federal Programs**

**Criteria:** The Uniform Guidance in 2 CFR Section 200.303 requires that non-Federal entities receiving Federal awards (i.e. auditee management) establish and maintain internal control designed to reasonably ensure compliance with Federal statutes, regulations, and the terms and conditions of the Federal award. The School should have a process in place to perform a review of the SEFA, to include evidence of the resolution of variances, as well as a process to document the overall review and approval to ensure proper presentation, completeness, and accuracy of the SEFA.

**Condition:** During the course of the audit, we noted there is no documentation of the review process of the SEFA to ensure accuracy and completeness.

**Status:** During 2023, the client has implemented a review process of the SEFA. However, there is no written documentation of the review process. This finding will be included in 2023-005.

#### **2022 -006 Approval Of Expense Reimbursement Submittals - Significant Deficiency - Activities Allowed Or Unallowed And Allowable Costs/Cost Principles**

##### **ALNs 84.425/84.425C/84.425D/84.425U - Elementary And Secondary School Emergency Relief Fund (ESSER)**

**Criteria:** The Uniform Guidance in 2 CFR Section 200.303 requires that non-Federal entities receiving Federal awards (i.e. auditee management) establish and maintain internal control designed to reasonably ensure compliance with Federal statutes, regulations, and the terms and conditions of the Federal award. The School has an internal control in place that expense reimbursement submittals on federal grants be approved by School management prior to their submission to the state for reimbursement.

**Condition:** During the course of the audit, the engagement team identified multiple instances where the support showing School management's approval of the expense reimbursement submittal for federal grants was unable to be provided.

**Status:** No similar findings were noted in the current year.



January 10, 2024

RubinBrown  
10801 W Charleston Blvd.  
Suite 300  
Las Vegas, NV 89135

In connection with the Single Audit of Somerset Academy of Las Veags (“the School”) for the year ended June 30, 2023, transmitted herewith is the Fiscal Year 2023 Corrective Action Plan in accordance with 2 CFR Section 200.511, *Audit Findings Follow-Up*. This schedule provides the status of the *Government Auditing Standards* and Single Audit findings for the 2023 fiscal year.

**Finding Number:** 2023-001 – Revenue Recognition and Accounts Receivable Aging

**Corrective Action Plan:** The error was missed due to the later than expected start of year end reconciliation review process caused by delayed 2022 single audits and financial audits. Management is doing a review of current staffing with the goal of increasing staff to ensure a timely and efficient year-end process.

**Personnel Responsible for Corrective Action:** Nachum Golodner, Academica Director of Accounting

**Anticipated Completion Date:** June 30, 2024

**Finding Number:** 2023-002 –Reconciliation of Accounts

**Corrective Action Plan:** The under accrual of payroll was caused by teachers and other employees having different contract terms. After a thorough review of contracts, management agrees with the finding, and will ensure to include all employees in future accruals in accordance with contract terms. The error in bond amortization was missed due to the later than expected start of year end reconciliation review process caused by delayed 2022 single audits and financial audits. Management is doing a review of current staffing with the goal of increasing staff to ensure a timely and efficient year-end process.

**Personnel Responsible for Corrective Action:** Nachum Golodner, Academica Director of Accounting

**Anticipated Completion Date:** June 30, 2024

**Finding Number:** 2022-003 and 2023-003 – Understatement of Bond Accrued Interest





**Corrective Action Plan:** The error was missed due to the later than expected start of year end reconciliation review process caused by delayed 2022 single audits and financial audits. Management is doing a review of current staffing with the goal of increasing staff to ensure a timely and efficient year-end process.

**Personnel Responsible for Corrective Action:** Nachum Golodner, Academica Director of Accounting

**Anticipated Completion Date:** June 30, 2024

**Finding Number:** 2022-004 and 2023-004 – Review of Capital Assets for the Removal of Fully Depreciated Items No Longer In Use

**Corrective Action Plan:** The error was missed due to the later than expected start of year end reconciliation review process caused by delayed 2022 single audits and financial audits. Management is doing a review of current staffing with the goal of increasing staff to ensure a timely and efficient year-end process. Management will review the fixed assets ledger during the next fiscal year to ensure any items that have been disposed of have been removed from the general ledger.

**Personnel Responsible for Corrective Action:** Nachum Golodner, Academica Director of Accounting

**Anticipated Completion Date:** June 30, 2024

**Finding Number:** 2022-005 and 2023-005 – Review and Approval of the Schedule of Expenditures of Federal Awards (SEFA)

**Corrective Action Plan:** While there was a review of the SEFA, the documentation of said review did not occur properly. Management has put in place a process to document preparation/review of the SEFA evidenced by signature and date.

**Personnel Responsible for Corrective Action:** Nachum Golodner, Academica Director of Accounting

**Anticipated Completion Date:** June 30, 2024

**SOMERSET ACADEMY OF LAS VEGAS  
FINANCE COMMITTEE  
SUPPORT SUMMARY**

MEETING DATE: **FEBRUARY 2, 2024**  
AGENDA ITEM: **3d – REVIEW AND RECOMMEND APPROVAL OF NORTH LAS VEGAS  
SHADE STRUCTURE**  
NUMBER OF ENCLOSURES: **1**

**SUBJECT: NORTH LAS VEGAS SHADE STRUCTURE**

**ACTION**  
 **CONSENT AGENDA**  
 **INFORMATION**  
 **PUBLIC HEARING**

**PRESENTER(S): GARY MCCLAIN**

PROPOSED WORDING FOR MOTION/ACTION:

**MOVE TO RECOMMEND APPROVAL OF THE NORTH LAS VEGAS SHADE STRUCTURE.**

FISCAL IMPACT: **NO**

ESTIMATED LENGTH OF TIME FOR CONSIDERATION (IN MINUTES): **3-5 MINUTES**

BACKGROUND:

**THE COMMITTEE WILL REVIEW AND POSSIBLY RECOMMEND APPROVAL OF THE NORTH  
LAS VEGAS SHADE STRUCTURE.**

## Somerset Academy of Las Vegas

### NLV Shade Structure

### Bid Process Summary

#### Objectives:

To secure quality bids by invitation. The invitation resulted in three qualified responses. Vendors contacted include Creative Play Recreation, Park Pro Playgrounds, Metro Awnings & Iron and Pro Playgrounds.

To concisely and accurately present results of the bidding process; including recommendations if any.

To support the Board of Directors in concluding this process by their selecting a provider for the specified project funded by SGF.

#### Bid Results:

<u>Contractor</u>	<u>Base Bid</u>
Park Pro Playgrounds	\$42,213.88
Creative Play Recreation	\$43,602.50
Pro Playgrounds (materials only) Installation by Muller Construction	\$58,600
Metro Awnings & Iron	No response

#### Recommendations:

**Approval of contract with low bidder, Park Pro Playgrounds for \$42,213.88 paid for through SGF.**



---

INSTALL

QTY	PRODUCT		
1	55' x 24' Fabric HIP shade structure	\$19,650.00	\$19,650.00

Notes **OPTIONAL PERMIT PROCUREMENT:**  
**Should client choose to have any applicable building permits obtained by Park Pro Playgrounds, a \$1000 permit procurement fee shall apply. Client understands and acknowledges that this fee is in addition to any permit fees, 3rd party inspection fees, and/or soils reports needed. The aforementioned fees will be paid by Park Pro Playgrounds with full reimbursement of costs to be paid to us prior to installation of shade structures. Initial Here\_\_\_\_\_** \*\*This estimate/proposal is for all of the work and materials outlined above and cannot be subdivided due to the discounts and efficiencies of scale which are built into the above estimate. Requests to proceed with only a portion of the above work will require the approval of a separate estimate/proposal before the work can proceed.

---

**\*\*FORTY-TWO THOUSAND TWO HUNDRED THIRTEEN AND 88/100 DOLLARS\*\***

**FOR THE SUM OF: \$42,213.88**

Above pricing includes any applicable taxes, freight and delivery costs. All materials with installation shall be delivered to the Park Pro warehouse. Any materials not including installation shall be delivered to the customer jobsite. Customer is responsible for the unloading, security and storage of these materials. This bid is based upon installation of equipment on a level surface provided by customer. Customer accepts title to the property FOB factory before the carrier physically delivers the property to the customer. No leveling or prep work of surface areas is included in this bid unless specifically noted. Preparation of sub grade to a level surface is an extra and will be billed at time and material. Hard digging costs are not included in this quote. Should a hand dig or hard dig be required additional costs of \$250 per hour shall apply. Third party inspections are not included in the above quote; any required third-party inspections shall be contracted and paid by owner. Owner is responsible for ensuring all underground utilities and irrigation lines are clearly marked prior to commencement of installation. Park Pro shall not be responsible for damages to unmarked underground items. Finished height of all equipment is based upon manufacturers' recommendations. Safety zone requirements shall be provided at time of contract – it is the customers' responsibility to maintain this perimeter. Park Pro is not responsible for customers' choice of safety surfacing. All material is guaranteed to be as specified. All work to be completed in a workmanlike manner according to standard practices. Any alteration or deviation from above specifications involving extra costs will be executed upon written orders, and will become an extra charge over and above this proposal. All agreements contingent upon accidents or delays beyond our control. Park Pro requires a minimum 7 business day notification to commence installation of any equipment. ASTM 1487-21 An inspection and maintenance program is a requirement of playground ownership. It is your responsibility as a playground owner/operator to inspect and maintain your equipment. Manufacturer warranties may not apply should a written maintenance of equipment not be available. This proposal is valid for 30 days from date above unless otherwise stated in writing.

---

PARK PRO PLAYGROUNDS: *Alyssa Domico/ms* DATE: January 16, 2024

---

**PROPOSAL ACCEPTANCE AND TERMS**

**CONTRACT OR PURCHASE ORDER INFORMATION**

TO: Academica  
INVOICE CONTRACT NAME: 2024-0116 Somerset Academy North Las Vegas

**Payment Terms:** Payment arrangements may be made via Cash, Credit Card (processing fee applies), Purchase Order or Contract. Customers requesting credit with some material suppliers must apply and be approved prior to order acceptance. Credit applications may be obtained from Park Pro Playgrounds. All orders for materials require a **100% material deposit before the order can be placed.** Material costs are due upon the receipt of the invoice. Labor will be billed on a percentage of completion basis with **NET 15 TERMS.**

**Shade Terms:** Soils reports to be provided by client. Changes to completed engineering/calculations resulting from a soils report being provided after the fact, may incur additional charges as dictated by the engineer. Concrete mix design letters are not included above and will be an additional \$450 if requested. Should a hand dig or hard dig be required additional costs of \$250 per hour shall apply. Hand digging or hard digging may apply when exposed utilities not shown on the Call before You Dig arise or if the ground is very hard from Caliche found in Southern Nevada. Permits can take anywhere between 2 weeks to an unknown amount of time due to the building department. Installation cannot be started until permits are obtained. Park Pro will work with the building department and Customer until they are approved. Shade over 600 Sq’ will require wet stamped grading plans. Grading plans, soils report and third-party inspections (QAA), should they be required are the Customers responsibility to obtain shall they be requested by the building department during the time the permit is pulled. Any costs incurred for these items shall be at the owner’s expense. **INITIAL HERE**\_\_\_\_\_

**Client hereby accepts all responsibility for reimbursing Park Pro Playgrounds for costs incurred during the permitting process, should the shade materials manufacturer be unable to provide proof of being a Clark County Approved Fabricator. Examples of such fees could be, but are not limited to: QAA fees and additional inspections, engineering changes from manufacturer required by municipality, product design changes required by municipality, special inspections by municipality, etc. Client is responsible for selection and contracting of third party QAA.**  
**INITIAL:**\_\_\_\_\_ **DATE**\_\_\_\_\_

**Acceptance:** I agree to the terms stated on the agreement and am duly authorized by project owner to approve and accept this order as stated.

**ACCEPTED BY:** \_\_\_\_\_ **DATE:** \_\_\_\_\_

**TITLE:** \_\_\_\_\_

**TOTAL PURCHASE AMOUNT:** **\$42,213.88**  
6440 Sky Pointe Dr. 140-173 Las Vegas, NV 89131  
Phone: (702) 254-4111 · Fax: (702) 454-1223

NSCB 52954 - \$300,000 LIMIT \* NSCB 75086 - \$250,000 LIMIT \* NSCB 90217 - \$45,000 LIMIT



Recreation

Contractors #0082534  
 Contractors #0082538  
 Contractors #0085733  
 Bid Limit - UNLIMITED

ALL PURCHASE ORDERS, CONTRACTS, AND  
 CHECKS TO BE MADE OUT TO:  
 Creative Play Recreation  
 140 S Fourth Street  
 Henderson, NV 89015  
 Phone: 702-400-2047

# PROPOSAL

January 8th, 2024  
 DATE

CONTACT: Nathan Dehoyos  
 COMPANY: Academica Nevada  
 PHONE: (832) 640-0584  
 FAX:

SHIP TO: **Please Advise**

BILL TO: **Please Advise**

Destination \_\_\_\_\_  
 F.O.B. \_\_\_\_\_

FREIGHT  Prepaid  Collect

**Net 30**  
 TERMS (Subject To Credit Approval By LSI)

**14-16 weeks with 50% Deposit from submittal/permit appr**

SHIPPING TIME

**Pricing Valid Through February 8th 2024**  
 All Other Pricing Good for 60 Days from Date of Proposal

We are pleased to submit this proposal to supply the following items:

QTY	ITEM NO.	DESCRIPTION	UNIT W	UNIT PRICE	WEIGHT	EXTENDED AMT
<b>Project Name: Somerset Academy North Las Vegas - Fabric Shade Structure</b>						
1	Rectangular Hipped	Shade N Net Rectangular hipped 6 column shade structure measuring 55' x 24' overall with an entry height of 8' and including the hardware, cables and powder coating	0	28,177.50 Tax Inclusive	-	\$ 28,177.50
1	Engineering	Wet sealed and stamped engineering drawings and calculation  Installation includes: excavations ( <b>no hard dig</b> ), supply and install rebar cages and hang anchor bolts and templates, supply and install concrete to footings, assembly, erection, labor and equipment  Excludes: building plan and permit application fees and 3rd party QAA fees if required  Non-Prevailing wages		1,625.00	-	\$ 1,625.00
<b>Total Weight</b>					-	
SUBTOTAL MATERIAL						\$ 29,802.50
<b>US COMMUNITIES DISCOUNT</b>						
INSTALLATION						\$12,300.00
FREIGHT						\$ 1,500.00
<b>TOTAL</b>						\$ 43,602.50

ACCEPTED BY CUSTOMER \_\_\_\_\_ DATE \_\_\_\_\_  
 \_\_\_\_\_ DATE \_\_\_\_\_

PRINT NAME \_\_\_\_\_



A80591 7,500,000.00  
 B78912 Limits 7,500,000.00  
 C3-83955 7,500,000.00  
 C4-83957 7,500,000.00

## PROPOSAL

To: Academica Nevada  
 6630 Surry St  
 Las Vegas NV 89119

Date: 01/26/2024

**Attention:** Nathan Dehoyos  
 Nathan.dehoyos@academicanv.com

Phone: 702 353-8402

**JOB NAME**

Somerset Shade Structure

**JOB ADDRESS**

Centennial  
 Las Vegas, Nevada 89128

Muller Construction is pleased to present the following bid.  
 Construction documents by Job Walk  
 All Materials related to this scope of work are furnished by Muller Construction.

**PROPOSAL SUMMARY AMOUNT**

**Shade structure**

Engineering fees to stamp plans for permit plus permit fees	\$7,250.00
Drill and install 6 post and foundation peers, Includes concrete and rebar	\$16,950.00
Receive and install shade structure (Purchase By Academica)	\$16,400.00
TOTAL ESTIMATED COST	\$40,600.00
15% supervision OH&P	\$6,090.00
<b>Total cost</b>	<b>\$46,690.00</b>

THIS PROPOSAL IS VALID FOR thirty (30) DAYS AFTER WHICH TIME WE RESERVE THE RIGHT TO REVISE, ALTER OR AMEND THIS PROPOSAL.



**General Exclusions:**

Bond, engineering, code upgrades, third party inspections, permits, overtime, shift work, water supply, clean out area, protection of existing or new work, repairs due to trade damage, any work not listed above.

**Qualifications:**

- This proposal shall be incorporated into and become a part of a standard construction contract document by addendum, attachment or exhibit for the purpose of defining inclusions, exclusions and qualifications.
- This proposal is based on a mutually developed and agreed upon construction schedule with all activities being performed in a logical sequence. Any changes to the schedule which result in work that is out of sequence shall incur additional costs.
- All building lay-out control lines and elevation benchmarks shall be provided by the General Contractor.
- This proposal provides for remediation of deficiencies in Work for one (1) Punch-list as prepared by the Owner. Any and all additional punch-list work will incur additional costs.
- Muller Construction. Accepts no responsibility for delays or associated costs for trade damage to our finished work, inspection delays, Owner changes or GC changes to the contract documents.

If you have any questions or concerns regarding your proposal, please feel free to contact me at any time at (702) 501-7137 or email me directly at [salva@mullerlv.com](mailto:salva@mullerlv.com)

**Steve Alva**

---

*Project Manager*

Muller Construction



**TRUST**  
— *the* —  
**EXPERTS**

For over a decade, our customers have entrusted us to provide safe and affordable playground and recreational equipment. Our team of Certified General Contractors and Playground Safety Inspectors will insure that your project is completed to perfection, providing truly turnkey service, with every step of the process from planning and budgeting, through the installation being handled under one roof.



1-800-573-7529 | [www.proplaygrounds.com](http://www.proplaygrounds.com)



Pro Playgrounds  
8490 Cabin Hill Road  
Tallahassee, FL 32311

### Quote

<b>Date</b>	<b>Estimate #</b>
1/8/2024	24520

<b>Project Name</b>
Shade



<b>Customer / Bill To</b>
Academica Nevada ATTN: Nathan DeHoyos 385 W Centennial Pkwy, North Las Vegas, NV 89084

<b>Ship To</b>
Academica Nevada ATTN: Nathan DeHoyos 385 W Centennial Pkwy, North Las Vegas, NV 89084



**WE WILL BEAT ANY PRICE BY 5%!**

Item	Description	Qty	Cost	Total:
CSSD	Furnish 36'x24'x8' hip shade with no installation  **SHADE STRUCTURE** Custom Shade Design - 36x24x8 four post hip shade	1	10,245.95	10,245.95
Shipping	Combined Shipping and Freight Charges	1	2,050.80	2,050.80
DSC	Discount valid until 1/31/24		-297.75	-297.75
NOTE: Customer responsible for unloading from freight carrier (forklift preferred). Installation not included.				

**AGREED AND ACCEPTED:**  
If the above total price, scope of work, specifications, terms and conditions are acceptable, sign below indicating your acceptance and authorization for Pro Playgrounds to proceed with the work and/or sales transaction described in this quotation. Upon signature and payment in accordance with this quote, Pro Playgrounds will proceed with the work and/or sales transaction.

\_\_\_\_\_/\_\_\_\_\_/\_\_\_\_\_  
Signature Name / Title Date

<b>Subtotal:</b>	\$11,999.00
<b>Sales Tax: (7.5%)</b>	\$0.00
<b>Total:</b>	<u>\$11,999.00</u>

Terms and Conditions - Price valid for 30 days and subject to change. 1. If installation is not included with your purchase, client will be responsible for coordinating, receiving and unloading of all goods, delivery drivers will not help unload goods. 2. Client will be responsible to inspect goods for defect, damage or missing parts, any deficiency or missing parts must be noted on delivery slip. 3. Client will be responsible for costs due to cancelled or missed delivery appointments. 4. Client has reviewed all items, colors and descriptions on this quote for accuracy and correctness. 5. If quote includes installation of goods, the installation is subject to the terms and conditions of Pro Playgrounds "Standard Installation Agreement" a copy of which may be obtained from your Sales Representative.

## Hip Shade

<b>Length</b>	36'	<b>Width</b>	24'	<b>Entry Height</b>	8'
<b>Peak Height</b>	12.85'	<b>Elbow</b>	Glide	<b>Column Mount</b>	Embedded
<b>Column Size</b>	Ø5.5" Sch-40	<b>Rafter Size</b>	Ø3.5" 11-Ga	<b>Ridge Size</b>	Ø3.5" 11-Ga
<b>Column Length</b>	11'	<b>Rafter Length</b>	17.06'	<b>Ridge Length</b>	13.76'
<b>Dome Qty.</b>	1	<b>Column Qty.</b>	4		

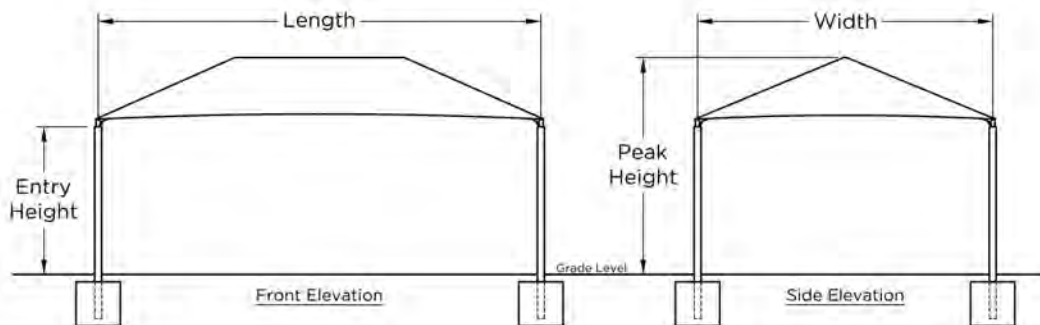
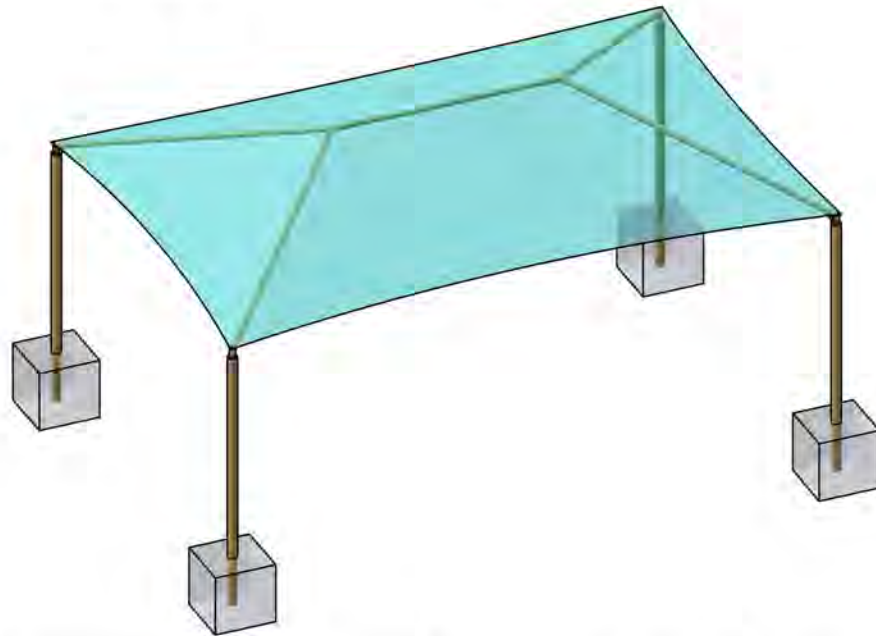

Square Footing		
Column	Length & Width	Depth
Single Cap	3.72	3
Double Cap	N/A	3

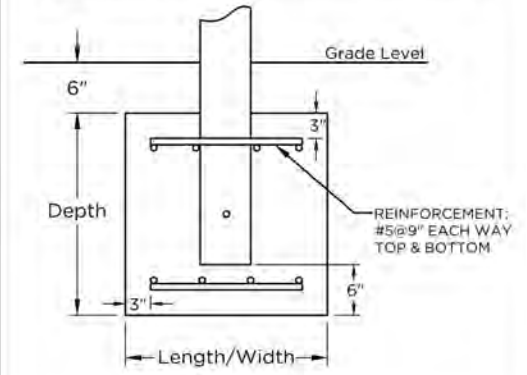

Auger Footing		
Diameter	Single Cap Depth	Double Cap Depth
1'-6"		
2'-0"	Out of range	N/A
2'-6"	Out of range	N/A
3'-0"	4.7	N/A

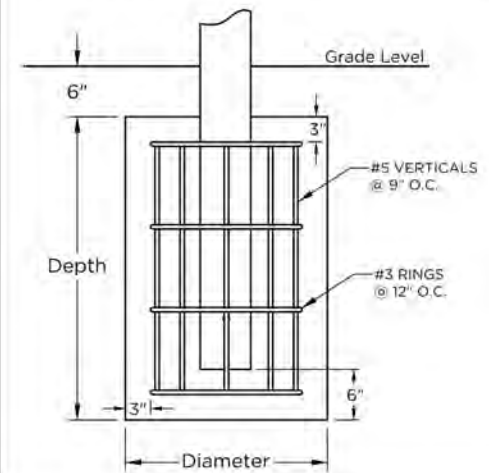

QUOTE

SHADE SIZE

36 X 24

SHADE STYLE

Hip Shade

# SHADE COLOR OPTIONS



## Frames

Backed by a [5-year limited warranty](#).

### Gloss

	Red		Royal Purple
	Orange		Burgundy
	Butterscotch		Beige
	Yellow		Vanilla
	Spring Green		Brown
	Chartreuse		Black
	Light Green		White
	Green	<b>Matte, Textured &amp; Metallic</b>	
	Sage		Champagne
	Sky Blue		Metallic
	Blue		Bronze
	Periwinkle		Starlight

## RainGuard Waterproof Shade Fabric

For our Single Post Waterproof Umbrella.  
Backed by a [10-year limited warranty](#).

Tan	White

## Traditional Fabric

This selection of fabric colors are California Fire Marshal certified, fire retardant, and pass the NFPA 701 or ASTM E84 tests. Colors marked with an asterisk are available as both flame retardant and non-flame retardant. Backed by a [10-year limited warranty](#).

Natural*	Beige	<b>NEW!</b> Desert Sand*	Latte	Rivergum Green*	Lime
Shade Factor: 76.2% UV Blocking: 93%	Shade Factor: 87% UV Blocking: 97%	Shade Factor: 86% UV Blocking: 93%	Shade Factor: 90% UV Blocking: 95%	Shade Factor: 88.7% UV Blocking: 92.9%	Shade Factor: 79% UV Blocking: 95%
Mint Green	Forest Green	Brunswick Green*	Turquoise*	True Blue	Sky Blue*
Shade Factor: 93% UV Blocking: 95%	Shade Factor: 94% UV Blocking: 96%	Shade Factor: 94% UV Blocking: 94.7%	Shade Factor: 86% UV Blocking: 91.5%	Shade Factor: 89% UV Blocking: 93%	Shade Factor: 89% UV Blocking: 92.2%
<b>NEW!</b> Aquatic Blue*	Navy Blue*	<b>NEW!</b> Royal Purple*	Sun Blaze	Cayenne*	Cedar*
Shade Factor: 85.6% UV Blocking: 91.1%	Shade Factor: 93.6% UV Blocking: 94.4%	Shade Factor: 87.7% UV Blocking: 91.1%	Shade Factor: 91% UV Blocking: 94%	Shade Factor: 85.3% UV Blocking: 92.4%	Shade Factor: 87.3% UV Blocking: 93.6%
Yellow*	Brown	Pearl Onyx	Silver	Steel Gray*	Midnight
Shade Factor: 77.6% UV Blocking: 95.5%	Shade Factor: 93% UV Blocking: 95%	Shade Factor: 86% UV Blocking: 94%	Shade Factor: 93% UV Blocking: 95%	Shade Factor: 90.9% UV Blocking: 94.3%	Shade Factor: 98% UV Blocking: 98%

## Dual Shade Fabric

Available for an upcharge for our Hypar Umbrella, Triangle Sail, and Hyperbolic Sail. Backed by a [10-year limited warranty](#).

Citrus	Sunburst	Macaw	Chameleon	Topaz	Amazonia
Shade Factor: 87% UV Blocking: 91.9%	Shade Factor: 75.2% UV Blocking: 90.6%	Shade Factor: 83.3% UV Blocking: 90.7%	Shade Factor: 86.4% UV Blocking: 90.3%	Shade Factor: 85.8% UV Blocking: 90.6%	Shade Factor: 91.1% UV Blocking: 92.4%
Savanna	Cobblestone	Gold Rush	Capri	Santorini	Maldives
Shade Factor: 80.1% UV Blocking: 92.3%	Shade Factor: 90.3% UV Blocking: 93.6%	Shade Factor: 88.3% UV Blocking: 91.5%	Shade Factor: 83.9% UV Blocking: 92.1%	Shade Factor: 83.3% UV Blocking: 92.2%	Shade Factor: 95% UV Blocking: 90.9%



**SOMERSET ACADEMY OF LAS VEGAS  
FINANCE COMMITTEE  
SUPPORT SUMMARY**

MEETING DATE: **FEBRUARY 2, 2024**  
AGENDA ITEM: **3e – REVIEW AND RECOMMEND APPROVAL OF LOSEE CAMPUS FIELD RENOVATIONS**  
NUMBER OF ENCLOSURES: **2**

**SUBJECT: LOSEE CAMPUS FIELD RENOVATIONS**

ACTION  
 CONSENT AGENDA  
 INFORMATION  
 PUBLIC HEARING

**PRESENTER(S): GARY MCCLAIN**

PROPOSED WORDING FOR MOTION/ACTION:

**MOVE TO RECOMMEND APPROVAL OF THE LOSEE CAMPUS FIELD RENOVATIONS.**

FISCAL IMPACT: **NO**

ESTIMATED LENGTH OF TIME FOR CONSIDERATION (IN MINUTES): **3-5 MINUTES**

BACKGROUND:

**THE COMMITTEE WILL REVIEW AND POSSIBLY RECOMMEND APPROVAL OF THE LOSEE CAMPUS FIELD RENOVATIONS.**

# GREEN LIVING SERVICES

4205 W. TOMPKINS, SUITE 4  
LAS VEGAS, NEVADA 89103  
Phone 702-367-TURF Fax 702-642-5724

## NEVADA LICENSES

C-10 LICENSE #66773, (LANDSCAPE) Monetary Bid Limit \$750,000  
C-40 LICENSE #68714, (SAFETY SURFACES) Monetary Bid Limit \$750,000  
C-25 LICENSE # 71769, (PLAYGROUND EQUIPMENT) Monetary Bid Limit \$750,000  
C-18 LICENSE # 75664 (MASONARY) Monetary Bid Limit \$750,000

January 30, 2024

### RE: SOMERSET LOSSE ACADEMY FIELD REPLACEMENT

Green Living Surfaces is pleased to submit the following proposal to remove the existing 108,000 sf Football field at Somerset Losee Academy and install all new SHAW LEGION PRO SYNTEHTIC TURF FOOTBALL/SOCCER FIELD.

**SHAW OMINA PARTNERS AGREEMENT NUMBER: R220504**

#### This project will include:

- (1) Complete removal and disposal of existing field
- (2) Laser regrading of sub-base including additional sub-base material where needed
- (3) Replacement of all perimeter nailer board where needed
- (4) Installation of 108,000 SF of all new high grade SHAW LEGION PRO synthetic turf including;  
108,000 sf of all new heavy duty SHAW SYNTHETIC TURF for new Football/Soccer Field including removal and disposal of the existing turf, laser regrading of the sub-base and adding new sub-base materials where necessary, adding new perimeter nail board where needed, all "Prevailing Wage" installation labor, football yard numbers, hash marks, sideline lines, end zone lettering per schools design, center field logo per schools design, SBR rubber/Sand infill mixture to meet High School Football/Soccer "HIC" requirements, all regulation Soccer lines and a full 8 year warranty.

**BASE PRICE \$626,868.00**

#### Options:

(a) Provide SHAW LEGION NXT 2.0 SYNTHETIC TURF-ADD	\$30,000.00
(b) Provide 104,000 sf of impact padding under new turf-ADD	\$96,000.00
(c) Provide NATURAL PLAY INFILL in lieu of SBR rubber infill- ADD	\$85,000.00
(d) Provide all new high school regulation Football Goal posts- ADD	\$32,000.00
(e) Provide Goal Post padding with school lettering and Logo- ADD	\$1,800.00
(f) Provide turf for Auxiliary area- 3,465 sf -ADD	\$17,325.00

Submitted by;  
Harry Jackson, VP  
702-367-8873  
GREEN LIVING SERVICES  
harry@greenlivingservcies.com



RENDERING NOTES

1. NONE

scale: - 1"=40'



PRODUCT: TBD
AREA: TBD
INFILL TYPE: RUBER/SAND
INFILL RATIO: TBD
INSTALLER: TBD

SOMERSET ACADEMY  
MULTI-SPORT  
NORTH LAS VEGAS, NV  
RENDERING

JOB #: #####  
DATE: 1/24/2024  
DRAWN BY:  
Roger Chastain

T 49 OF 15 SHEET



Academy | Losee Campus

Somerset Academy

147 ft

Imagery Date: 12/19/2022 36°14'37.70" N 115°06'49.75" W

NOT FOR PRODUCTION

COPYRIGHT © 2015 - SHAW SPORTS TURF (ALL RIGHTS RESERVED)

C:\Users\rchastal\OneDrive - shawinc.com\2024 Estimates\Somerset Academy - JB17 Takeoff\Dwgs\240123 - Somerset Academy - TO1

## Manufacturer's Limited Product Warranty

Shaw Integrated and Turf Solutions, Inc. Shaw Sports Turf<sup>®</sup> endeavors to use the highest quality materials and the latest manufacturing techniques in the production of our Synthetic Turf products. Our products are manufactured within our product tolerances which permit Shaw Sports Turf<sup>®</sup> to offer a guarantee against defects in materials and workmanship with respect to Shaw Sports Turf<sup>®</sup> Synthetic Turf products for a period of eight (8) years from the date of Substantial Completion.

The term Synthetic Turf, as used herein, shall include only the synthetic turf fibers and backings supplied by Shaw Sports Turf<sup>®</sup>.

Synthetic Turf is a consumable product and is subject to normal wear and tear, which is not a manufacturing defect and is not covered by this warranty. In addition to the factors mentioned above, wear and tear depends on, without limitation, the construction of the Synthetic Turf, the intensity of use of the Synthetic Turf and climate. Shaw Sports Turf warrants that the Synthetic Turf Fiber will be considered to have maintained UV stability if the weight of the Fiber shall not have decreased by more than ten percent (10%) per year according to ASTM standards, nor exceed fifty percent (50%) during the warranty period as a result of normal and ordinary wear and tear with properly maintained infill levels as required. The Fiber shall be stable to excessive fading and will fade in a uniform manner with no significant color variation except as affected by changes resulting from pile distortion, normal matting, and high wear areas.

NOTWITHSTANDING ANYTHING TO THE CONTRARY CONTAINED IN THIS LIMITED WARRANTY, THIS LIMITED WARRANTY SHALL NOT COVER ANY DEFECTS, FAILURE IN OR DAMAGE TO THE SYNTHETIC TURF THAT IS:

- (a) due or attributable to intentional and unintentional abuse, misuse, negligence;
- (b) installed, repaired, altered or replaced by any person not authorized by Shaw Sports Turf.
- (c) damaged, directly or indirectly, including but not limited to, on account of, accident, vandalism, machinery, inappropriate footwear including track spiked shoes, metal spiked cleats, animals, misuse, fire, flood, war, chemical reactions, acts of God, static or dynamic loads exceeding Shaw Sports Turf<sup>®</sup> specifications, improper cleaning methods or improper maintenance and grooming;
- (d) exposed to light other than natural light or approved artificial light; or
- (e) damage caused by excessive heat sources, engine exhaust, field heaters or other secondary reflective light.
- (f) not maintained in accordance with Shaw Sports Turf<sup>®</sup> maintenance manual and recommendations, including the care and maintenance of the infill system and proper infill levels (if applicable). The purchaser shall keep a log of all maintenance performed on the Product and supply Shaw Sports Turf with a copy upon request.
- (g) caused by normal and ordinary wear & tear or concentrated high wear areas
- (h) attributable to the base and any and all resulting damage to the product arising therefrom due to, failure or improper design of the base, infiltration rates, depressions or settlement of the base, long term planarity and/or compaction of the base upon which the product is installed, improperly prepared subgrade or subgrade settlement.
- (i) caused by thermal expansion and contraction of the sub-base, pad, drain tile or changes in the water table.
- (j) results from use for any purpose other than those approved in writing by Shaw Sports Turf

THE EXPRESS WARRANTIES SET FORTH IN THIS LIMITED WARRANTY ARE IN LIEU OF AND EXCLUDE ANY AND ALL OTHER WARRANTIES, EXPRESS OR IMPLIED, INCLUDING, BUT NOT LIMITED TO ANY IMPLIED WARRANTIES OF MERCHANTABILITY OR FITNESS FOR A PARTICULAR PURPOSE.

No person or party is authorized to create any obligation or liability for Shaw Sports Turf<sup>®</sup> and only the limited warranty expressed herein shall apply.

Shaw Sports Turf's obligations under this limited warranty are restricted to the repair or, at Shaw Sports Turf's sole option, replacement of all, or the affected parts covered herein. Shaw Sports Turf's liability under this limited warranty is limited to the prorated replacement value (based on an 8 year period) of the item to be repaired or replaced. IN NO EVENT SHALL THE OBLIGATIONS OF SHAW SPORTS TURF<sup>®</sup> UNDER THIS LIMITED WARRANTY EXCEED THE PURCHASE PRICE OF THE PRODUCT.

The remedy of repair or replacement set forth herein shall be the sole and exclusive remedy of the Warranty Holder and Shaw Sports Turf<sup>®</sup> shall have no other obligations or liability in connection with any matter or thing, including without limitation, the condition or quality of the Synthetic Turf. WITHOUT LIMITATION OF THE FOREGOING, IN NO EVENT SHALL SHAW SPORTS TURF<sup>®</sup> BE LIABLE TO THE WARRANTY HOLDER OR ANY OTHER PARTY FOR ANY INDIRECT, SPECIAL, INCIDENTAL OR CONSEQUENTIAL DAMAGES CONNECTED WITH THE USE OF THIS PRODUCT, INCLUDING, WITHOUT LIMITATION, CLAIMS FOR DAMAGES RELATING TO PERSONAL INJURY, LOST TIME OR CONVENIENCE, LOSS OF USE OF THE PRODUCT, LOST PROFITS OR REVENUES, DOWNTIME COSTS, THE LOSS OF PERSONAL OR COMMERCIAL PROPERTY, THE COSTS OF TELEPHONE, TRAVEL OR LODGING, OR ANY OTHER DAMAGES.

Shaw Sports Turf<sup>®</sup> endeavors to handle all warranty claims promptly and professionally. The obligations of Shaw Sports Turf<sup>®</sup> under this Limited Warranty are conditional on Shaw Sports Turf<sup>®</sup> having been paid in full with respect to this project, including all change orders at the time of claim.

### Notification of Claims

You, the Warranty Holder, will contact your Shaw Distributor or Shaw Sports Turf representative for claim service. Claims under this warranty must be submitted in writing and a detailed description of the issue, along with photographs showing the concern. The Shaw Sports Turf representative will file a claim via [shawsportsturf.claims@shawinc.com](mailto:shawsportsturf.claims@shawinc.com) and submit the information you provided. A company representative will thoroughly evaluate your claim. If you have any questions contact Shaw Financial Services, P O Box 2128, Dalton, GA 30720 or by phone, 1-800-257-7429.

It is agreed that all claims by the Warranty Holder made under the foregoing limited warranty shall be invalid unless made in writing to Shaw Sports Turf<sup>®</sup> within eight (8) years from the date of Substantial Completion and within (30) days of learning of the defect giving rise to its claim.

This Limited Warranty is not transferable.

Issued to: \_\_\_\_\_  
As Warranty Holder

Project Name: \_\_\_\_\_

Installation Location: \_\_\_\_\_

Date of Substantial Completion: \_\_\_\_\_

# LEGION PRO™

## HYBRID SYNTHETIC TURF SYSTEM



				SPECIFICATIONS			
SYSTEM COMPONENT	TEST	ASTM TESTING PROCEDURE	UNIT	LEGION PRO 1.75	LEGION PRO 2.0	LEGION PRO 2.25	LEGION PRO 2.5
Yarn	Linear Density - Total Denier*	D1577-07	denier	15,800	15,800	15,800	15,800
	Thickness - Mono**	D3218-07	microns	300	300	300	300
	Thickness - Tape**	D3218-07	microns	100	100	100	100
	Break Strength - Mono***	D2256-10	lbs / force	20	20	20	20
	Break Strength - Tape***	D2256-10	lbs / force	12	12	12	12
	Elongation - Mono & Tape	D2256-10	%	> 30	> 30	> 30	> 30
	Total Lead Content - Mono & Tape	F2765-14	ppm	< 100	< 100	< 100	< 100
Turf Fabric	Total Product Weight****	D5848-10e1	oz / yd <sup>2</sup>	68	74	78	84
	Pile Yarn Fiber Weight**	D5848-10e1	oz / yd <sup>2</sup>	40	46	50	56
	Primary Backing Weight**	D5848-10e1	oz / yd <sup>2</sup>	8	8	8	8
	Secondary Backing Weight†	D5848-10e1	oz / yd <sup>2</sup>	20	20	20	20
	Average Pile Height**	D5823-13	inches	1.75	2.0	2.25	2.5
	Average Tuft Bind Strength	D1335-12	lbs / force	> 10	>10	> 10	> 10
	Tufting Gauge	D5793-05	inches	1/2	1/2	1/2	1/2
	Average Grab Tear Strength	D5034-09	lbs / force	> 200	> 200	> 200	> 200
Turf System	g-Max	F355-10a		< 165	< 165	< 165	< 165
	Pill Flammability	D2859-06 (2011)		Pass	Pass	Pass	Pass
	Infiltrometer (Drainage)	BS 7044 Method 4	in / hr	> 25	> 25	> 25	> 25

Except where noted as a minimum or maximum, the above specifications are nominal.

\* All values are ± 8% \*\* All values are ± 5% \*\*\* All values are ± 25% \*\*\*\* All values are ± 10% † All values are ± 3 oz

© 2021 Shaw Sports Turf

## ProPlay-25

### Technical data sheet

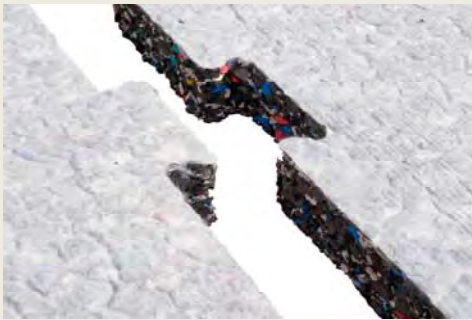

ProPlay-25 is designed to protect playing children against heavy head injuries.

ProPlay-25 is installed under for instance artificial grass and makes it an impact absorbing surface. For a prompt installation, the ProPlay-25 is supplied as interlocking panels.

#### Physical characteristics

ProPlay-25 consists of thermal bonded (closed-celled) cross-linked Polyethylene foam (PEX). This foam comes from production residues and contains no contaminants.

ProPlay-25 is tested based on microbiological resistance (according EN 12225) resistance to: weathering (according EN 12224), oxidation (according EN ISO 13438), acids & bases (according EN 14030). The predicted durability of PEX is a 100 years minimum (according ISO/TR 13434). ProPlay-25 is tested on durability at the German test institute I.S.P.

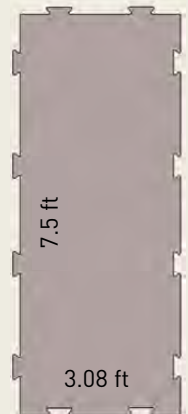

#### Technical data

##### Physical

Thickness at 0,3 psi (2kPa) load	1,06	in	
Mass per unit area	0,55	lb/ft <sup>2</sup>	

##### Performance

Critical fall height (Head Injury Criterion ~ 1000)	2,6	ft	ASTM F 1292 / EN 1177
-----------------------------------------------------	-----	----	-----------------------

##### Drainage and isolation

Thermal conductivity [ $\lambda_{10}$ ]	0,03	BTU/hr.ft.°F	ASTM C 177 / EN 12667
(resulting) Thermal resistance [R-value]	3066	hr.ft <sup>2</sup> .°F/BTU	ASTM C 177 / EN 12667

The provided information is, to the best of our knowledge, true and accurate (at the time of revision). This information is based on (independent) measurements and (where possible) based on average values, measured over a long and representative period. Additional information (e.g. additional characteristics, specific (independent) reports or statistical analysis) is available upon request. Schmitz Foam Products is allowed to change this information and/or the product (without notice) and assumes no legal responsibility for use of and/or reliance on this information.



**safe**shell<sup>®</sup>  
SPORTS



**SAFESHELL**, the low maintenance natural infill option made of 100% USA-grown walnut shells. Through a patent pending process, the residual allergens from the nut are thoroughly removed from the walnut shell. Safeshell excels at reducing surface heat, creating a firm and fast surface, and ensuring peace of mind for field users.

## RECOMMENDED SYSTEM

### Why You Should Follow Our Recommended System:

We believe that choosing your infill is the most critical decision you will make when it comes to investing in a synthetic turf field. Remember to start your field planning with the selection of infill so your system components, such as turf height and face weight, are optimized for the infill.

<b>Turf Type:</b>	Slit Film <b>or</b> Slit & Monofilament Blend
<b>Turf Fiber Face Weight:</b>	46 oz (1590 g/m <sup>2</sup> )
<b>Turf Fiber Height:</b>	1.75" (44 mm)
<b>Ballast Layer of Raw, Round Sand:</b>	±5.0 lbs/ft <sup>2</sup> (24 kg/m <sup>2</sup> )*
<b>Shock Pad:</b>	Required
<b>Performance Layer of Safeshell:</b>	1.5 lbs/ft <sup>2</sup> (7.3 kg/m <sup>2</sup> )*

\*Exact quantity to be verified based on specific turf and desired fiber reveal.



## SAFESHELL, THE NATURAL CHOICE

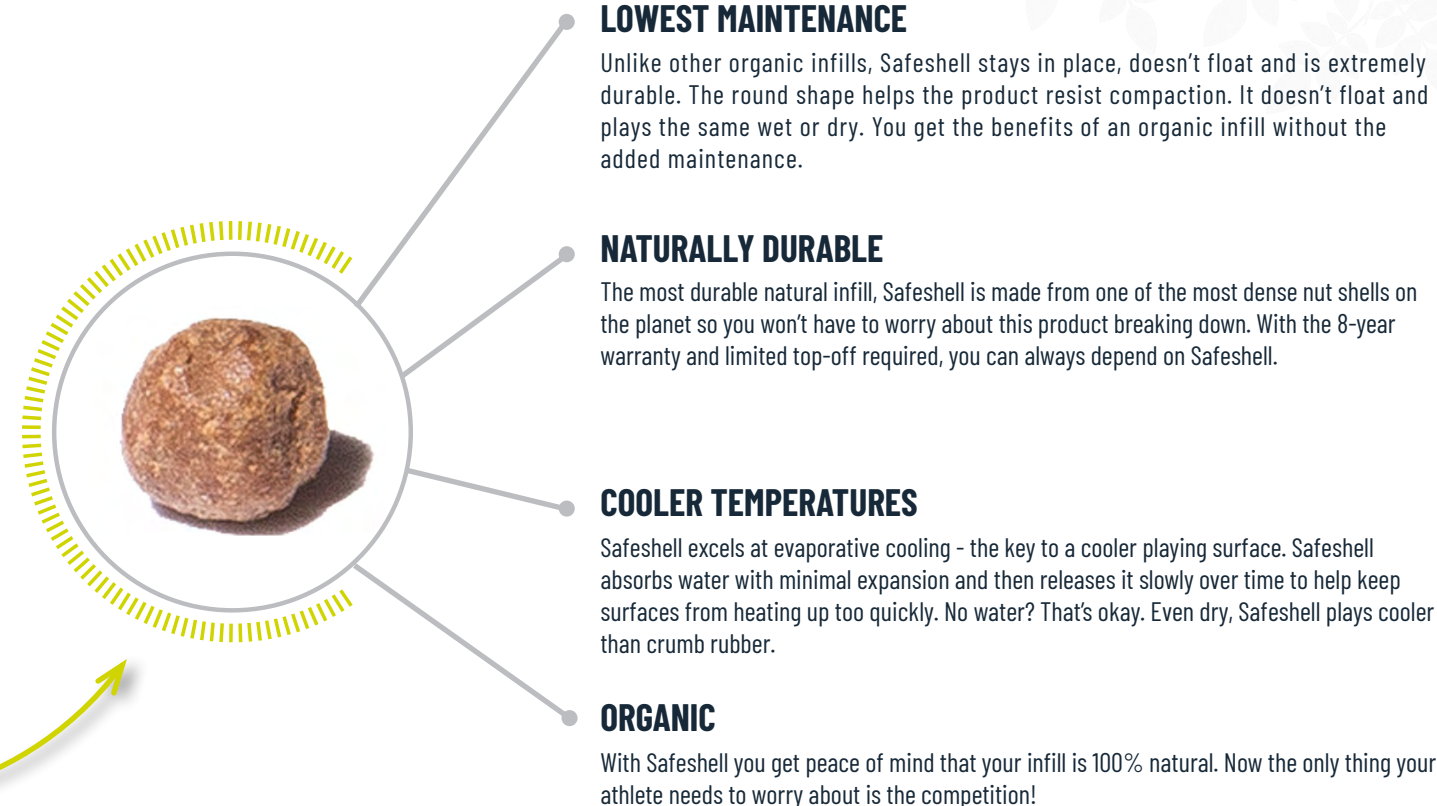

# SAFESHELL TESTING



## MAINTENANCE

- Our products are the lowest maintenance infills on the market which can help save field owners time and money.
- Simply put, Safeshell and Envirofill are heavier than the other turf infills, and they don't float. This means they stay put in the turf fibers regardless of climate or hours of field play.
- Infill staying in place is extremely important when thinking about the maintenance of a synthetic turf field. Safeshell and Envirofill won't migrate, won't float away, and won't fly out.
- This also helps limit the amount of additional infill field owners must buy because they will not need to top off as much.

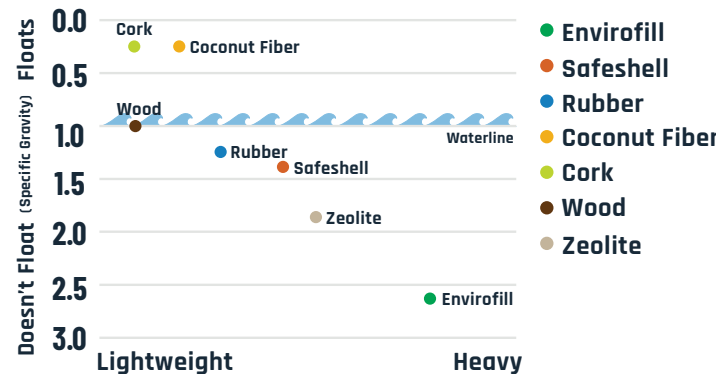

## SURFACE TEMPERATURE

- Safeshell excels at cooling fields and doing so either wet or dry. When exposed to water through rain or dew, it has the ability to absorb moisture into its cellulose structure and release it slowly to cool the fibers.
- Safeshell has very low solar absorptivity, the measure of how much heat it will absorb from solar radiation.

FIFA14

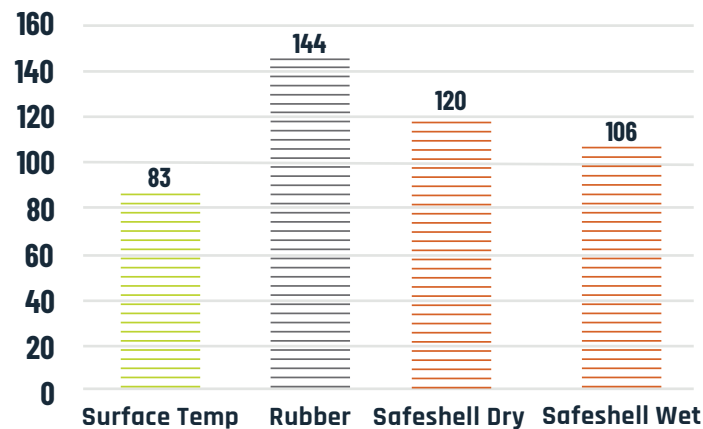

## ABRASION

- The shape of a particle has a lot to do with abrasion, even more than particle firmness. Safeshell and Envirofill's smooth, round shape score quite well compared to a similar system with crumb rubber.
- The rounded particles create less resistance as one slides over the surface.

ABRASION ASTM F1015

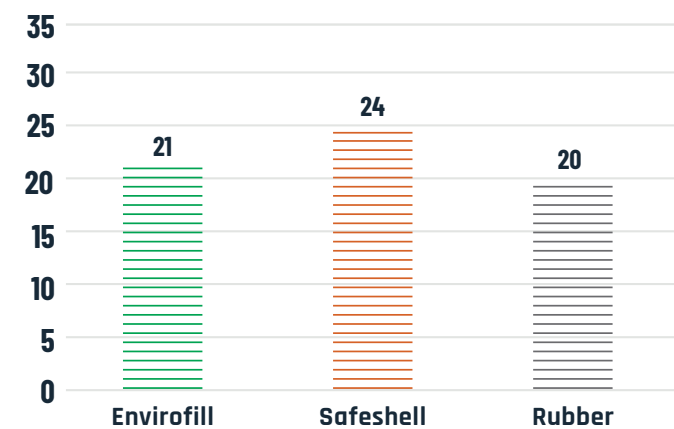

## DURABILITY

- A durable infill is one that has minimal breakdown. This chart provides a comparison as to what you can expect between infills with different characteristics. The percentage represents how much each material resisted breakdown. The higher the percentage, the more product you will retain over the life of your field and the less you will need to replenish or top-off with more infill. The lower the percentage, the more material was lost due to the breakdown of the product.

MICRO-DEVAL ASTM D7428

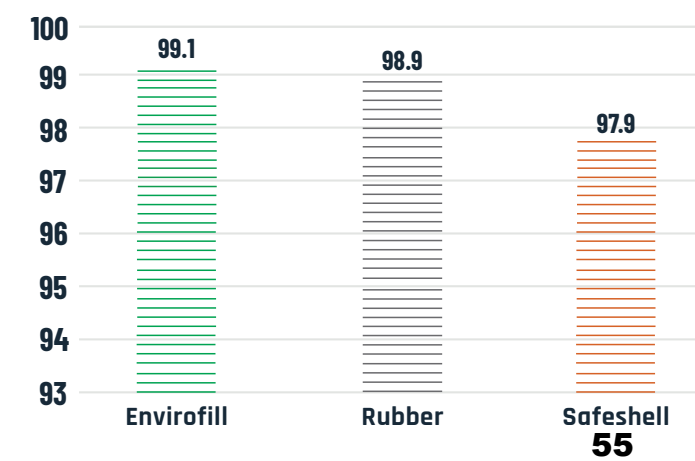

## FIELD PERFORMANCE TESTING



### BALL REBOUND

- Systems with Envirofill or Safeshell fall within the FIFA range of ball rebound.
- This indicates that players will find as they move from a high performing natural field to a synthetic turf system with one of these infills, the ball bounce will be realistic and predictable.

FIFA RANGE: 0.6 - 1.00 m

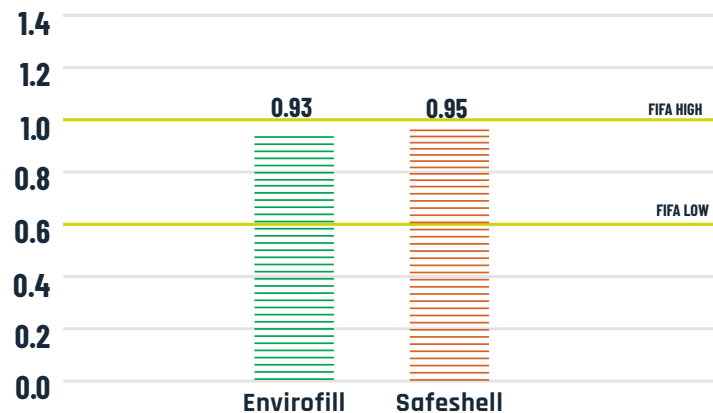

### SHOCK ABSORPTION

- Shock Absorption is a measure of surface hardness. The score represents the percentage of energy absorbed by a surface. A 0% surface would be concrete while a 100% surface is a trampoline. FIFA's ideal range is 57% to 68%. While systems with Envirofill feel firmer under foot than a system with crumb rubber, they are very safe and absorb the right amount of shock for the athlete.

FIFA RANGE: 57 - 68%



### TRACTION

- The ideal amount of traction is well... ideal! Safeshell and Envirofill provide just the right amount of traction due to their uniform shape and smooth edges. The uniform particles allow for cleats to dig into the infill but not lock. The desired FIFA range is 27 - 48 Nm.
- Other factors that can affect traction are the types of cleats and amount of free fiber.

Rotational Resistance

FIFA RANGE: 27 - 48 Nm

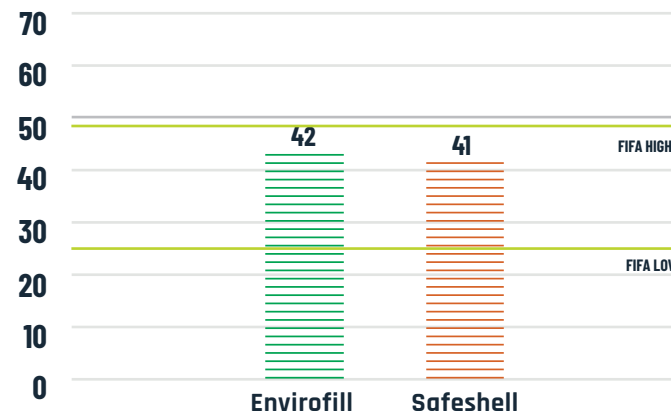

### VERTICAL DEFORMATION

- Safeshell and Envirofill are different because they mimic the firmness of a sand-based natural turf system which has just the right amount of give when running and will absorb an impact when falling.
- In our recommended system, Safeshell and Envirofill perform well within the range and will do so consistently over the life of the field.

FIFA RANGE: 4 - 11 mm

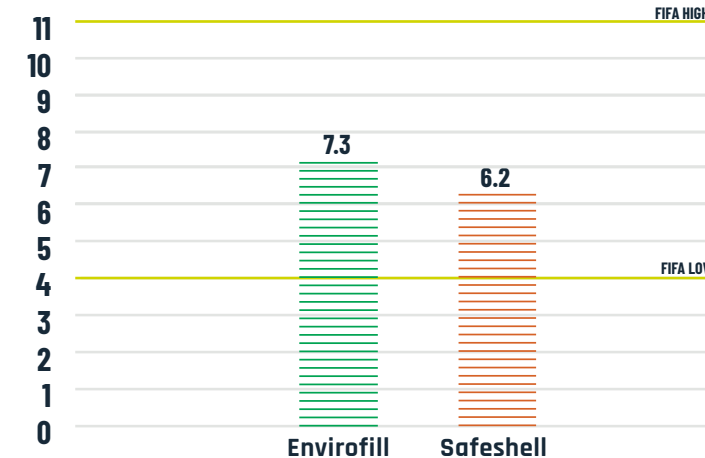





## SAFESHELL PROJECT SPOTLIGHT

**The Wheeler School**  
Seekonk, Massachusetts

The Wheeler School in New England installs **First of its Kind Turf Field** with infill made from walnut shells.

*"Safeshell has lived up to our expectations as being low-maintenance, durable, and safe. All of the parents' questions surrounding the topic of Safeshell and allergens were answered thoroughly by USGreentech. No issues have surfaced since the athletes have been playing on the field. The three words we would use to describe our experience with Safeshell in the first six months are: natural, easy, and dependable."*  
- **Gary Esposito, Director of Operations**



### The Details:

**Year Installed:** 2018  
**Application:** Multi-purpose  
**Turf:** 1.75" (44mm) Dual Fiber  
**Pad:** 17mm Shock Pad

MULTI-USE

### The Challenge:

The Wheeler School wanted to build a new synthetic turf field on their remote athletic campus which is adjacent to the upper watershed of Runnins River. It was important that the infill selected not negatively affect the downstream water quality. It was also critical that the infill was not difficult to maintain or create a burden that would take the focus away from maintaining the other seven natural fields on campus.

### The Solution:

The Wheeler School took a hard look at seven infill options and narrowed the decision to Envirofill and Safeshell. Ultimately, Safeshell was selected because it was a natural product, ideal for the field location adjacent to a nature preserve and required much less maintenance than the other natural infills.



**Regis University**  
Denver, Colorado

Regis University is the first University in Colorado to use **Safeshell**.

*"This field has received high marks for multiple sports on the way it performs and how balanced the pure roll of the ball is for soccer. Our Lacrosse team is extremely happy with the field performance. After three months the field still projects great balance when the players perform on it. I have installed eight artificial high performance fields in my career and this is the best one yet with the infill portion. We also feel safer with our athletes playing on a sustainable safe field."*  
- **Michael J. Redmond, Associate Vice President, Physical Plant / Capital Projects**

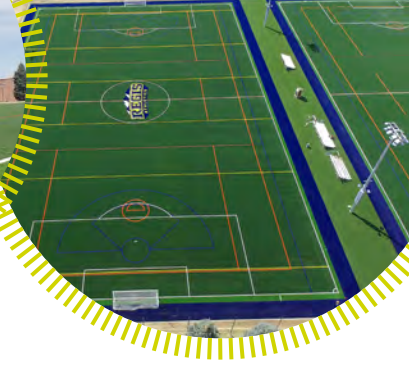

### The Details:

**Year Installed:** 2021  
**Application:** Multi-Purpose  
**Turf:** 1.75" (44mm) Dual Fiber  
**Pad:** 23mm Shock Pad

MULTI-USE

### The Challenge:

Regis University was looking to update its multi-purpose field. They were looking for infill that would protect the turf field surface and playability. The safety and performance of Regis University's multi-purpose sports fields were important in the decision-making process.

### The Solution:

Safeshell provided a natural, safe, and low-maintenance infill that would keep this multi-purpose field functioning for years to come. A unique feature of this multi-purpose field was a landscape artificial turf was installed between the two fields to serve as a distinction between the fields and play surface. Safeshell was used for this distinctive line of landscape artificial turf.



## QUESTION CORNER

### FREQUENTLY ASKED QUESTIONS ABOUT SAFESHELL

#### How should it be described?

Safeshell is a synthetic turf infill made out of a proprietary blend of English and Black walnut shells.

#### Why was it developed?

Safeshell was developed to address many of the concerns of organic infills on the market. Unlike other organic infills, Safeshell is highly durable, low maintenance and plays the same wet or dry. It boasts many advantages over other organic infills in terms of performance. It stays in place, doesn't float, and is extremely durable. The round shape of each grain helps the product resist compaction.

#### What are the benefits?

Safeshell 100% USDA Certified Biobased Product that is extremely durable and requires minimal maintenance. It experiences limited degradation over its lifetime. Unique to the natural infill category, Safeshell does not require irrigation and does not float, meaning migration of the product is very limited. Actually, tests have shown that Safeshell performs the same wet or dry. Safeshell does allow for evaporative cooling and can reduce surface temperatures by up to 38 degrees when compared to a crumb rubber field.

#### How does Safeshell perform differently from other natural infills like cork, coconut, and wood?

Because Safeshell is highly durable, low maintenance, and performs the same wet or dry, it boasts many advantages over other organic infills in terms of performance. Many organics without very specific management and care can break down and create a less than optimal field, especially with age. Safeshell has been developed to address many of these performance concerns.

#### What is a shock pad?

In selecting Safeshell, a shock attenuation pad is also required. The shock attenuation pad ensures the field has adequate shock absorption over its entire life. Shock pads also provide another layer of protection against concussions.



#### How is Safeshell different from other natural infills?

Safeshell is superior to other natural or organic infills due to its durability. Unlike other natural infills, Safeshell won't float and won't blow away. Any breakdown experienced happens at a much slower pace. It's sturdy enough to stay in place and maintain a consistent playing surface for athletes. Many natural infills require watering or their warranty requires a certain percentage of moisture content at all times. Safeshell plays the same wet or dry making it the most low-maintenance organic infill product. Sourcing 100% in the U.S. ensures top quality and makes it the most sustainable product on the market.

#### What about people with allergies?

Safeshell is an allergen-free product. We teamed up with a leading biotechnology firm to develop a patent-pending process that eliminates allergens that remain on the shell after separation from the nut. Following FDA guidelines, our process removes allergens below 2.4 parts per million. Safeshell is regularly subjected to third-party analysis by an ISO-certified food testing laboratory to ensure that the product is allergen-free and absent of trace amounts of walnut protein.

#### How does the cost of Safeshell compare to other natural infills?

Safeshell is lower cost than other natural infills. While it is comparable to other natural infills at installation, it will be less costly to maintain due to its high durability (less top off) and high bulk density and weight (stays in place). It also does not require irrigation.

#### How durable is Safeshell?

Safeshell is the most durable natural infill, made from one of the hardest nut shells on the planet so you won't have to worry about this product breaking down prematurely. It doesn't float and it's heavier than other natural infills which means there will be limited migration of the product and it will stay in place in rain storms and high winds. Many organic infills without very specific management and care can breakdown and create a less than optimal field. Safeshell has been developed to address many of these performance concerns. With the 8-year warranty and limited top-off required, you'll depend on Safeshell.



**safeshell**  
By  **MOTZ**  
[safeshellinfill.com](http://safeshellinfill.com)





SPORT SURFACES, INSTALLATION, AND RELATED MATERIAL  
Executive Summary

**Lead Agency:** Region 4 Education Service Center

**Solicitation:** 22-05

**RFP Issued:** August 26, 2021

**Pre-Proposal Date:** September 16, 2021

**Response Due Date:** October 5, 2021

**Proposals Received:** #7

**Awarded to:** Shaw Industries, Inc.

Region 4 Education Service Center issued RFP 22-05 on August 26, 2021, to establish a national cooperative contract for Sport Surfaces, Installation, and Related Material.

Scope Overview –

- Sport Surfaces, Installation, and Related Material. Each Awarded Offeror may offer their complete product and service offering, or balance of line.
- Awarded Contractor(s) may use unit prices established for the contracts specified by the latest version of the RSMeans Construction Procurement Catalog when provided Sport Surfaces, Installation, and Related Material products and services.
- Should an Awarded Offeror utilize distributors and/or dealers that have been approved, Participating Public Agencies may choose to issue work directly to the distributor and/or dealer if allowed by the Awarded Offeror and Participating Public Agency.

Cooperative Language -

The solicitation included cooperative purchasing language in Section I. Scope of Work and Appendix D: *Region 4 ESC, as the Principal Procurement Agency, defined in APPENDIX D, has partnered with OMNIA Partners, Public Sector (“OMNIA Partners”) to make the resultant contract (also known as the “Master Agreement” in materials distributed by OMNIA Partners) from this solicitation available to other public agencies nationally, including state and local governmental entities, public and private primary, secondary and higher education entities, non-profit entities, and agencies for the public benefit (“Public Agencies”), through OMNIA Partners’ cooperative purchasing program. Region 4 ESC is acting as the contracting agency for any other Public Agency that elects to utilize the resulting Master Agreement. Use of the Master Agreement by any Public Agency is preceded by their registration with OMNIA Partners (a “Participating Public Agency”) and by using the Master Agreement, any such Participating Public Agency agrees that it is registered with OMNIA Partners, whether pursuant to the terms of a Master Intergovernmental Cooperative Purchasing Agreement, a form of which is attached hereto on APPENDIX D, or as otherwise agreed to. APPENDIX D contains additional information about OMNIA Partners and the cooperative purchasing program.*

Advertisement -

Notice of the solicitation was sent to potential offerors, as well as advertised in the following:

- Region 4 Education Service Center website
- OMNIA Partners website
- USA Today, nationwide
- Arizona Business Gazette, AZ
- San Bernardino Sun, CA
- Honolulu Star-Advertiser, HI
- The Advocate – New Orleans, LA
- New Jersey Herald, NJ
- Times Union, NY
- Daily Journal of Commerce, OR
- The State, SC
- South Carolina website/newsletter (get from Chris White)
- Houston Community Newspapers, Cy Creek Mirror, TX
- Deseret News, UT
- Richmond Times, VA
- Seattle Daily Journal of Commerce, WA
- Helena Independent Record, MT
- Kennebec ME Journal

Socio-economic Outreach -

To encourage participation of small businesses, minority owned businesses and women owned businesses, Texas Historically underutilized Businesses were notified of the Request for Proposal.

Procurement Details -

On October 5, 2021 proposals were received from the following offerors:

- AstroTurf Corporation
- Elite Sports Builders LLC
- FieldTurf USA, Inc.
- KYA Services, LLC
- Mid-American Golf and Landscape, Inc. DBA Mid-America Sports Construction
- Shaw Industries, Inc.
- Softline Solutions

The proposals were evaluated by an evaluation committee. Using the evaluation criteria established in the RFP, the committee elected to enter into negotiations with Shaw Industries, Inc. and proceeding with contract award upon successful completion of negotiations.

Geographic Preferences: No geographic preferences were included in the evaluation of the responses.

Region 4 Education Service Center, OMNIA Partners, and Shaw Industries, Inc. successfully negotiated a contract, and Region 4 Education Service Center executed the agreement with a contract effective date of April 1, 2022.

Scope Details -

Complete turnkey surfacing providing synthetic solutions for:

- Sports
- Commercial
- Residential landscaping
- Pet facilities
- Parks
- Playgrounds
- Landfill closures

Projects are completed from start to finish with:

- Product Consultation
- Specification & Design Support
- Construction Consultation
- Product Management
- Removal/Ground Preparation
- Logo Positioning & Field Markings
- Infill Placement
- Field Inspection
- Maintenance & Care
- Synthetic Sports Turf Installation

Federal Funds Certifications -

The Supplier provided federal funds certifications. The signed federal certifications and contract provisions can be found in Exhibit F of the Supplier’s response, incorporated by reference into the Master Agreement, available on the OMNIA Partners website for review.

Term -

Initial three-year agreement from April 1 through March 31, 2025 with the option to renew for two (2) additional one-year periods through March 31, 2027. The anticipated full term of the contract is five (5) years.

*The Contractor shall have the right to enter local “service” agreements with Participating Public Agencies accessing the contract through OMNIA Partners, so long as the effective date of such agreement is prior to the expiration of the Contract. All local agreements may have a full potential term (any combination of initial and renewal periods) not to exceed five years. Any tasks or project agreements executed against this Master Agreement during the effective term may survive beyond the expiration of the Master Agreement as established and agreed to by both parties.*

Pricing/Discount -

Available upon request.